

ENERGY SENTRY®

9388B

Technical Manual

**Computerized Energy
Management**

a product of
BRAYDEN
AUTOMATION

The logo for Brayden Automation, featuring a stylized starburst or arrowhead shape composed of several parallel lines radiating from a central point.

9388B

Quick Start Guide

How to Decrease Your Electric Bill (and Increase Your Savings)

Open the cover of the Energy Sentry unit. Rotate the control knob until the upper 2-digit display reads “dL”. This represents your demand limit. Press and hold the black pushbutton switch on the left and immediately turn the control knob counterclockwise to a lower demand limit, depending on how much you wish to save.

If you are using the Time-Of-Use features of the 9388B, you may wish to double-check that the clock on your 9388B matches the clock setting on the meter. To do this, turn the control knob until the upper 2-digit display reads “CL” for “clock”. Compare the time settings. If a change is necessary, see Adjusting the 9388B on page 21 regarding how to set the clock.

How to Increase Your Comfort (and Increase Your Electric Bill)

Open the cover of the Energy Sentry unit. Rotate the control knob until the upper 2-digit display reads “dL”. This represents your demand limit. Press and hold the black pushbutton switch on the left and immediately turn the control knob clockwise one “click”. This will increase the controller’s demand limit by 0.5 KW.

Wait one or two hours to give the building a chance to heat or cool. If the change you just made does not feel sufficient, then press the pushbutton switch and turn the control knob clockwise another 0.5 KW. Repeat until satisfied. Don’t expect instant results. It may take several hours to fully realize the increase of the demand limit that you have just made. Remember, each KW increment that you increase the demand limit “dL” costs you additional money on your electric bill. Turn off all non-critical loads in your building to make more power available for heating and cooling loads. For more information and how to set the demand limit, please refer to page 23.

If you are using the Time-Of-Use features of the 9388B, you may wish to double-check that the clock on your 9388B matches the clock setting on the meter. To do this, turn the control knob until the upper 2-digit display reads “CL” for “Clock”. Compare the time settings. If a change is necessary, see page 23 regarding how to set the clock.

Note: For all other system adjustments, please see Section 6: Programming on page 32.

Section 1: Introduction and Overview of Demand Control

Thank you and congratulations on your decision to purchase the Energy Sentry Model 9388B Electrical Demand Management System. As the owner or operator of a demand metered building, you fall into a special group of consumers who can lower their monthly electric bills by reducing electrical demand peaks. You may be billed on either a “Straight” 24/7 Demand Rate or a Time-Of-Use (TOU) Demand Rate to enable the 9388B to work for you. Additionally, you may be on an Energy Rate with no separate demand charge. If you’re on this type of rate, the 9388B will limit your demand to keep you from exceeding the threshold of the next higher rate class. In all cases, the 9388B will work to reduce your electric bills.

Your decision to purchase a 9388B represents a sound and intelligent investment that will repay you over the years to come in reduced electric bills, added convenience and peace of mind. The 9388B is the most user-friendly electrical demand management system on the market today. It is important for you to have a good understanding of how this system works and how it will save you money. Further, you have certain responsibilities to ensure that your system is successful in delivering the results expected. Therefore, please read this manual thoroughly to gain an understanding of what the system will and will not do and to become proficient in adjusting the system when necessary to insure your savings and comfort.

Demand Billing Rates

Not all electricity costs the same. The reason for this is the different billing rates that your utility offers. Depending on the size of your business, you may have one, two or even three rates to choose from. Most likely, you will be billed on a "Demand" rate, which has an additional charge for demand.

Demand is defined as the rate of electric use as measured over a demand interval. Your peak demand is the highest rate of usage measured over all demand intervals during the billing period. In simple terms, the peak demand is the single demand interval in the billing period in which energy use exceeds all other demand intervals.

In addition to regular Demand Rates, many utilities offer demand-based Time-Of-Use (TOU-D) Rates that charge different amounts for energy-use depending on the time of day that the electricity is used. When these rates are applied to a specific customer's energy-use profile, costs can vary widely. Energy Time-of-Use (TOU-E) rates cannot be used with the 9388B.

Traditional or “Straight” Demand Rates

Traditional demand rates have been used to bill commercial and industrial electric customers for many years. In fact, it is the most common method of billing for these types of customers. Rates vary from utility to utility, but in general consist of small, medium and large general service rates. These rates usually calculate demand using a 15-, 30- or 60-minute averaging period, 24 hours a day, seven days a week (15-minute averaging is the most widely used). Nearly all Medium (MGS) and Large General Service (LGS) Rates include a demand component in the electric bill. However, in most Small General Service (SGS) Rates, there is no separate demand charge until a minimum threshold is reached. This minimum threshold typically varies from 10 KW to 50 KW. Once this threshold is exceeded, demand charges apply or you may be subject to a different rate class depending on the utility and its rates. The savings, by using a demand management system with these traditional rates, is achieved by simply reducing the peak demand during your building’s high-use time(s) of the day or night. On these rates, your building’s peak may or may not be at the same time as the utility’s peak and it does not matter since you are being billed on a 24/7 demand rate.

Time-Of-Use (TOU) Rates

Time-Of-Use Rates were developed by utilities to discourage energy-use during high-use or “peak” (also called “on-peak”) times of the day and week, and encourage electricity use during the low use or “off-peak” times of the day. In general, utilities charge a high rate for both energy (KWh) and demand (KW) during the “peak” times of the day and a cheaper rate during “off-peak” times. In addition, weekend days are generally off-peak times. If you are billed on a TOU Demand Rate, you may save substantially more by also shifting energy usage to off-peak times. Energy Sentry’s 9388B Demand Management System enables you to reduce these peaks while maintaining efficient use of energy under your current demand limit.

Different Meters

Traditional Demand and TOU Demand Rates require different meters than energy-only rates because of the way in which the rates work. Energy-only meters only measure kilowatt-hours consumed. These meters can only be used on non-demand rates since they cannot measure or record demand. Traditional demand meters may be mechanical, electronic or a combination. These meters record the total energy consumed and the highest usage over a 15-, 30- or 60-minute demand interval (depending on the utility). This highest rate of usage is your peak demand. TOU Demand meters separately keep track of the on-peak and off-peak kilowatt demand and the on-peak and off-peak kilowatt-hour usage. Depending on the way your utility’s TOU Demand Rate is structured, your meter may or may not record off-peak demands. On-peak hours vary from utility to utility, as well as by season.

To benefit from your Energy Sentry 9388B Demand Management System, *you must A) have a demand measuring electric meter and be billed on an appropriate electric rate (either Traditional or TOU) from your utility; or B) have a demand-measuring electric meter and be billed on an energy-only rate with the goal of staying below the utility’s rate class threshold.* Visit your utility’s website to view rate sheets or call your utility company to get details on the electric rates that may be applicable to your building. We recommend that you read your metered demand on the day of, or the day prior to, the meter reading by the power company to verify that your setting matches the meter’s reading.

Where Energy Sentry® 9388B Technology Comes In

If it were humanly possible to continuously and manually turn off heating or cooling circuits and equipment to level out peak demand, you wouldn’t need a demand management system to take advantage of the demand-based rate offered by your utility company. Remember, one slip in any one demand interval and your utility bill would reflect a high demand charge for the whole billing period. The 9388B takes over this difficult, continuous burden for you. The 9388B is one of the most sophisticated products available for controlling electrical peak demand. The 9388B is your 24-hour/7-day electrical system watchdog. When properly used, it can result in significant savings.

Section 2: System Description

The Energy Sentry 9388B is the most advanced, easy-to-use commercial demand management system on the market today. It features microcontroller technology, combined with years of demand control experience. The demand management system's flexible software control algorithms represent years of research, development and testing. The features of the 9388B have been developed with user friendliness and reliability as primary objectives. Major features of the 9388B are listed in the following section.

Superior Features of the 9388B

Regular or Time-of-Use Demand Control

The 9388B contains a real-time clock that allows the demand management system to take advantage of TOU Demand Rates available from some utilities and modify the control strategy accordingly. This feature can enhance the money savings and comfort capabilities of the 9388B. However, the 9388B may be used with "Straight" or Regular Demand Rates as well, making it a versatile tool that can be modified or changed if the type of billing rate changes.

Demand Limit Automation

The 9388B includes Auto-Limit capability, a feature designed to automate your demand limit changes. The 9388B's demand limit can be changed automatically up to 12 times a year to maximize your savings. You'll never have to worry about forgetting to change your demand limit again since Auto-Limit will do it for you. You set the desired demand limit and dates that you want the demand limit changed, and the 9388B's Auto-Limit will do the rest. If you prefer, Auto-Limit can be disabled so that you can change demand limits yourself whenever you wish.

Unmatched Digital Display Capability

The 9388B incorporates a large 6-digit LED display for an unmatched information presentation. The system displays all settings and real-time measurements, as well as the current time. All system measurements and settings are displayed by easy-to-read and remember mnemonics, two letter symbols, representing the current information on the display. See Appendix B for a listing of all system settings and displays.

Choice of Demand Control Algorithms

The 9388B allows one of five demand control algorithms to be selected, which determine how conservatively the system controls loads. This feature allows you to balance your desire to save money against enhanced comfort, taking into account the type of building, its operating pattern and type of controlled loads.

Sixteen Separate Control Points

High peak demands occur when several electrical loads are used simultaneously. The 9388B controls up to sixteen individual electric loads on separate control points (or more if multiple relays are used or loads are grouped). The appliances and equipment controlled can be turned off for brief periods of time with little or no interruption of your comfort and convenience. These loads typically are heating or cooling circuits and hot water heaters. Other loads that may be appropriate for control are those large loads that are a high percentage of the total demand, loads that run intermittently and loads that can be turned off for short periods without any loss of comfort and convenience. Depending on your installation, these loads may be responsible for as much as 60% to 80% of your total connected electrical load. With 16 separate control points, the 9388B provides maximum utilization of energy within the demand limit you have set. That's because the loads that are managed are smaller, permitting a more regular and even demand level. This results in greater energy efficiency and comfort.

Microcontroller for Maximum Accuracy and Reliability

Use of a microcontroller allows the 9388B to precisely measure power, compute KW demand, and accurately control the peak demand. In addition, by using a microcontroller, a built-in diagnostic program continually checks that all systems within the 9388B are functioning properly.

Non-Volatile Memory for Maximum Flexibility

The Energy Sentry's "remembers" all system settings, even when power is lost to your unit. In this way, utility power interruptions do not affect the settings in your 9388B. The system's 10-year non-volatile memory retains settings for 10 years in absence of power; and if power is lost, timekeeping continues for 10 years to ensure that the system clock is always accurate.

Choice of Load Control Strategies

The choice of load control strategies, made possible by the use of a microcontroller, offers unlimited flexibility as to how loads may be controlled. This means the 9388B can be adapted to virtually any application and load requirement. The priority of each control point can be individually set to create the optimum strategy for your particular application.

Minimum-On/Off Times to Protect Heat Pumps, Air Conditioners & Other Motor Loads

All 16 control points of the 9388B can be programmed with minimum-on and -off times, each variable from zero to 20 minutes. This feature allows the 9388B to be used with heat pump, air conditioning and motor loads by providing compressor timing protection.

RS-232C Serial Port

For advanced applications, the 9388B contains an RS-232C serial port for use with Brayden Automation Corporation's EnergyAccess® Windows software.

System Components

Your Energy Sentry 9388B Demand Management System consists of one or more components depending on the exact model ordered. The main component is the Control Unit and comes in three basic configurations depending on the power measuring input. They are: The 9388BA for single-phase current transformers, the 9388B3* for 3-phase current transformers, and the 9388BP for KYZ Pulse inputs. All three configurations are included in this manual. The system diagrams in Figure 2.0 thru 2.2 show basic examples for each of these configurations and generally how these components are connected to control loads.

While your 9388B measures all of the power used by your building, it controls only those loads to which it is connected. These loads will vary depending on the application and should be listed in Appendix C at the end of this manual. If you are in doubt as to which loads are controlled, ask the electrician or authorized dealer who installed your 9388B.

The basic function of your 9388B in controlling these loads is to keep the total electrical demand below a peak value that is set according to your desired level of comfort and minimum load requirements. Each of the 9388B's components has a separate and unique function in accomplishing this task as described on the following pages.

**Note: 9388B3 is configured as either a WYE (9388BY) or DELTA (9388BD). 9388B3 refers to the 3-phase model in general and includes both configurations.*

Figure 2.0 - 9388BA System Diagram

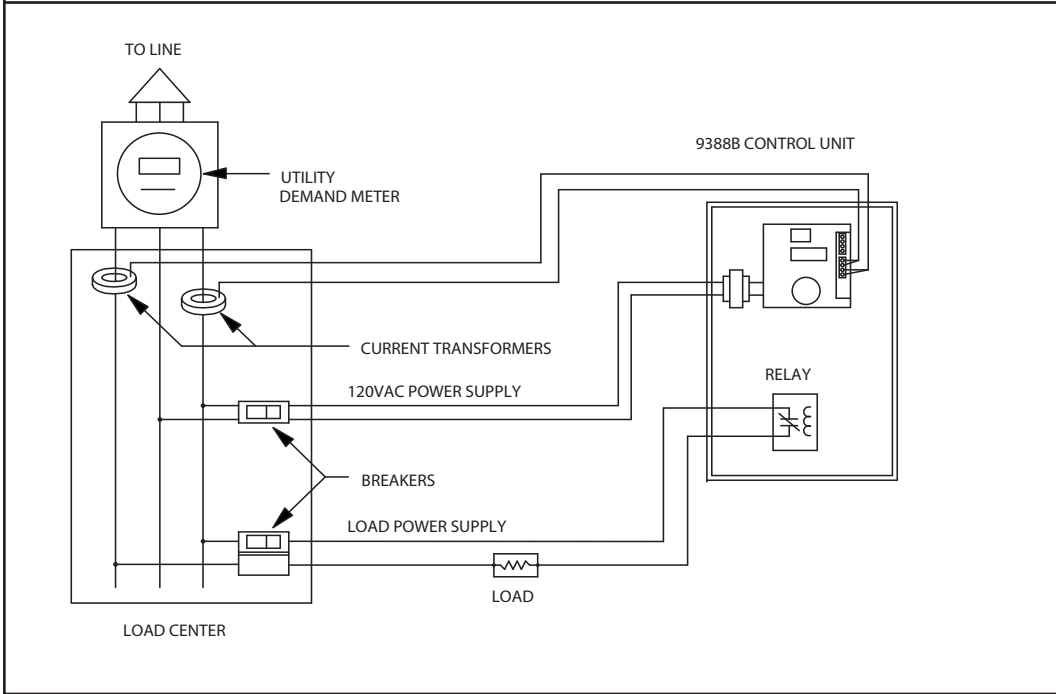
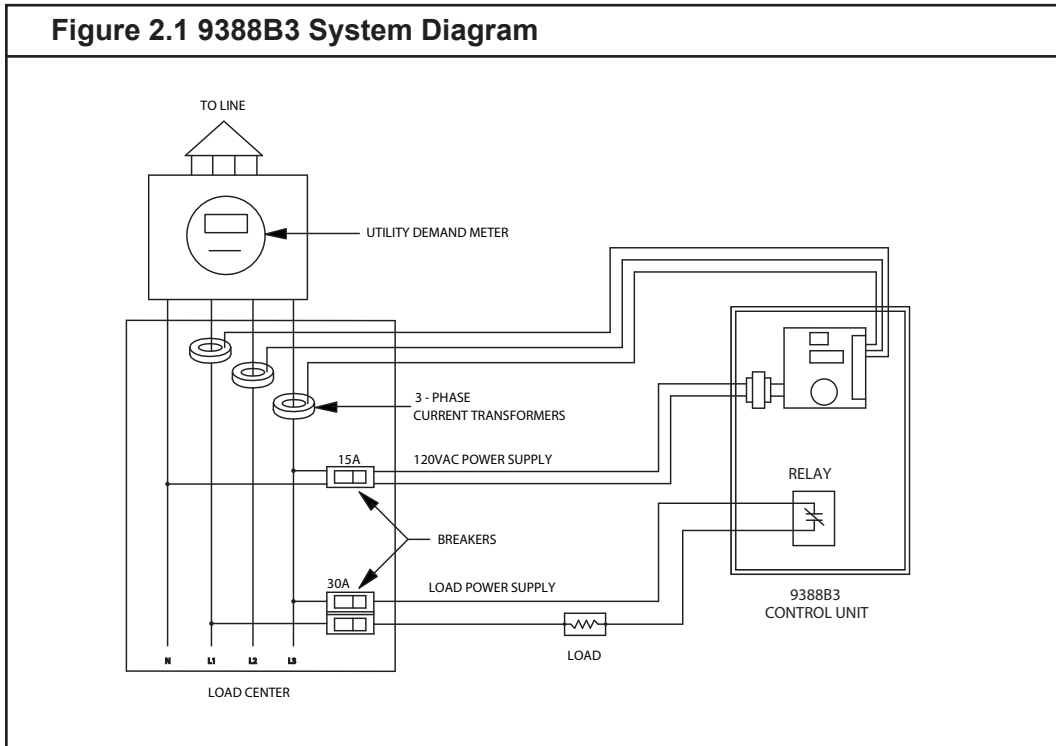
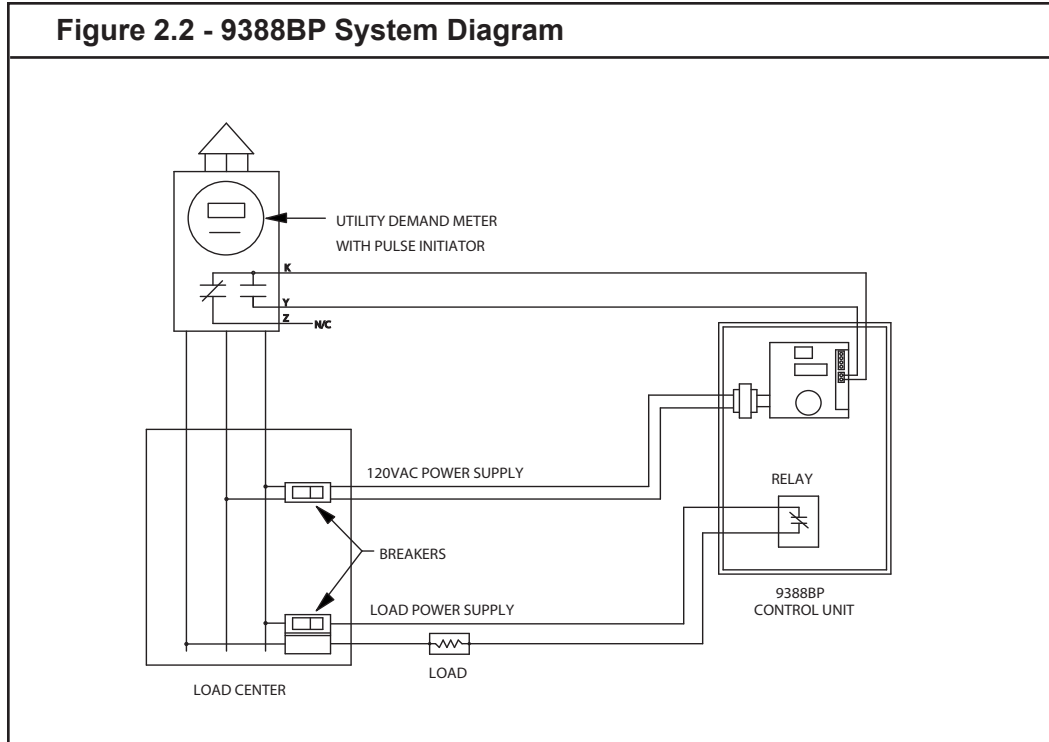

Figure 2.1 9388B3 System Diagram





Control Unit

The Control Unit consists of a Microcontroller/Logic Unit and up to 8 relays. The controller is typically mounted in an electrical room where access to the incoming power lines or the pulse meter is convenient. A control knob with an increase/decrease scale is provided to set all system settings. By using this control knob with the pushbutton switch, you can increase or decrease the demand level to balance savings with comfort. A 6-digit display provides system information and time. Your 9388B is one of the following models depending on the input configuration ordered:

9388B Models

9388BA	Single-Phase Current Transformer Input
9388B3*	Three-Phase Current Transformer Input
9388BP	Pulse Input

*can be configured for WYE (9388BY) or DELTA (9388BD)

Current Transformers

Current transformers (CT's) are usually mounted inside the main circuit breaker panel or electrical service entrance and serve to monitor total electrical usage. They measure the total electric current being drawn by all of the loads in your building. By monitoring the total usage, controlled loads may be turned on and off to keep total demand below the limit you set. The 9388BA includes 2 current transformers (1 pair) while the 9388B3 includes three CT's (1 set). The 9388B3 3-phase configuration requires the Model 9331 3-phase power adapter board configured for either a Wye or Delta service. See Section 10 for a complete description on 3-phase Power Monitoring. If your unit is equipped with a pulse input, current transformers are not needed and therefore are not included.

Pulse Input

The 9388BP is configured with an input to read “KYZ” pulses directly from the utility’s electric meter, thereby eliminating the need for any current transformers. The 9388BP supplies a low 9VDC wetting voltage to the dry-contact KYZ switch or pulse initiator in the meter. As the meter’s pulse initiator toggles open and closed in proportion with power use, the 9388BP times these pulses and computes the instantaneous demand. The faster the pulses occur, the higher the level of demand. This method offers superior demand accuracy since pulses are supplied by the meter. See Section 9 “Using the Pulse Input” for complete information on the pulse input power monitoring.

Relays

All 9388B models are supplied with 8 standard control point outputs on the Main Control board to control relays. Up to 8 relays may be connected to the system. There are four different kinds of relays that may be connected to the system:

Because commercial demand control applications vary widely with the equipment to be controlled, only a few relays are equipped standard in the Control Unit. The 30 Amp double pole relays are the default relay used in all 9388B models, but any one of the four relays available can be used for a particular application. Power relays are generally mounted in the Control Unit but can be mounted remotely near the load to be controlled. More information on relay options can be found in the "Determine Load Control Method" on page 9.

Relay Options

35 Amp Single-Pole Power Relay	P/N:	09200-60001A
30 Amp Double-Pole Power Relay*	P/N:	09200-60002A
3 Amp Single-Pole Low-Voltage Relay	P/N:	09200-62100A
5 Amp Double-Pole Low-Voltage Relay	P/N:	09200-62200A
		*default

Wirelynx® Powerline Carrier (PLC)

As an option, the 9388B can use the Wirelynx Powerline Carrier System to control loads using the building’s existing electrical wiring. The PLC system communicates on/off relay commands from a transmitter mounted in the Control Unit to receivers mounted around the building, usually near, in or on the load to be controlled. There are four different receivers available. Information about the installation, setup, and operation of this system is contained in the Wirelynx Powerline Carrier system manual.

PLC Receiver Options

PLC Receiver, 1 Ch., 3 Amp Single-Pole Low-Voltage Relay	Model LX1021A-111CSEB
PLC Receiver, 2 Ch., 5 Amp Double-Pole Low-Voltage Relay	Model LX1022A-211CSEB
PLC Receiver, 1 Ch., 30 Amp Single-Pole Power Relay	Model ES1031A-131BSEA
PLC Receiver, 2 Ch., 30 Amp Double-Pole Power Relay	Model ES1024A-231BCIB

Section 3: System Planning

The first and most critical step in achieving a successful installation is system planning. Turn to the system planning form in Appendix D, and use it to identify the power monitoring method needed, all controlled loads, how they will be controlled, and their priority setting.

Determine Power Monitoring Method

Determine how the unit will measure power. Most likely you have already determined this, as your 9388B would have been ordered with the power monitoring method needed for this application. The three methods are:

- Single-phase current transformers – determine either 40 or 80 KW full scale
- Three-phase current transformers – determine 50, 100 or 200 KW full scale
- Pulse initiator input from electric meter – determine full scale and pulse constant

Note: Make sure that you have all parts necessary to complete the installation.

Identify Controlled Loads

Survey your building and write down, in the order of importance, each load that will be connected to the system. These loads include all air conditioning and heat pump compressors, electric heat strips, water heaters and any other load that will be controlled. If there are more loads than active control points on the demand management system, group all loads in groups of the same type and approximate size.

Identify Each Load's Priority

Go through the list of controlled loads and write down a priority number from 1 to 16 for each load, where 1 is the most important and 16 is the least important. If two loads have the same priority, write the same number for each. Make sure the list is sequential so that there are no missing priority numbers in the order. It is not necessary to use all priority numbers all the way down to Priority 16.

Identify Time Delays for Compressors

All inductive loads, such as A/C or heat pump compressors, must have an off-time delay of 4 or more minutes. Review the list of all loads and place a 4, 5, or 6 in the “Minimum-Off Time” blank, depending on compressor size. For small units (1 or 2 tons), use 4 minutes. For medium units (3 or 4 tons), use 5 minutes and for larger units (5 tons or greater), use 6 minutes.

Minimum-on time delays should also be used on inductive loads. This is the minimum amount of time that the 9388B will leave the load on and let it run, before shedding the load again. This setting allows compressors to run long enough to do some useful work. As before, mark a 5, 6, or 7 for small, medium and large units, respectively, on the form under the “Minimum-On Time” blank for each controlled load. Keep these times as short as possible.

Determine Load Control Method

Next, determine how each load will be controlled. You will find a matrix of eight check boxes for each load in Appendix D. Each check box corresponds to a specific way in which to control each load. These are from left to right:

- Low-Voltage Single Pole Relay – used to interrupt a low-voltage control circuit (i.e. thermostat circuit). Rated up to 120VAC/35VDC @ 3 Amps.
- Low-Voltage Double Pole Relay – used to interrupt two low-voltage control circuits at the same time,

- or perhaps two different parts of the same control circuit. Rated up to 120VAC/35VDC @ 5 Amps.
- High-Power Single Pole Relay – used to interrupt a high-power electrical circuit (i.e. water heater circuit). Rated up to 277VAC/28VDC @ 35 Amps.
 - High-Power Double Pole Relay – used to interrupt two high-power electrical circuits at the same time (i.e. two resistive heat circuits). Rated up to 277VAC/28VDC @ 30 Amps.
 - Low-Voltage Single Channel Powerline Carrier Receiver – used to control low-voltage control circuits. Rated up to 120VAC/35VDC @ 3 Amps.
 - Low-Voltage Two Channel Powerline Carrier Receiver – used to control two low-voltage control circuits independently. Rated up to 120VAC/35VDC @ 3 Amps.
 - High-Power Single Channel Powerline Carrier Receiver – used to control line voltage circuits directly up to 30 Amps.
 - High-Power Two Channel Powerline Carrier Receiver – used to control two line voltage circuits directly up to 30 Amps.

Making Load Schedule & Control Point Assignments

Now that you've identified the controlled loads and how they will be controlled, prepare the load schedule identifying which loads will be connected to which control points. The load schedule is a listing of all of the electrical equipment that you intend to control. Use the form provided in Appendix D. List the controlled loads generally in the order of priority starting with the most important load(s) and working down to the least important load(s). The 9388B is equipped with 8 control point outputs and each of these outputs drives one or more relays from the list on page 9.

Table 3.0 - Load Connection Example

Control Point #	Load Priority	Load Description	Relay Type
1	3	Water Heater #1	N/C Internal Power
2	1	AC #1 (Compressor)	N/C On-Board LV
3	2	AC #2 (Compressor)	N/C On-Board LV
4	2	AC #3 (Compressor)	N/C Remote LV
5	4	Heat #1	N/C Remote Power
6	5	Heat #2	N/C Remote Power
7	6	Heat #3	N/C Remote Power
8	3	Water Heater #2	N/C Remote Power

Typical Load Schedule

Table 3.0 gives an example of a small commercial application with 3 heat pumps and 2 water heaters. Compressors and backup heat are controlled separately. A/C #1 and AC #2 are connected directly to the low voltage relays in the 9388B. Water Heater #1 uses a power relay mounted in the 9388B. The remainder are connected using remote relays. Your application may be different and require a variation of this example. Contact your Energy Sentry Representative or the factory for applications assistance.

Section 4: Installation

This section contains instructions for installation of the Energy Sentry 9388B Demand Management System. In order to ensure proper installation and warranty coverage, please read this manual thoroughly before proceeding with the work. Make sure you have all the required relays, current transformers and other equipment needed for this installation.

Note: All wiring must be installed in accordance with national and local electrical codes.

Tools and Materials Required

Tools Required:

- Wire cutter/Stripper
- Standard Flat Blade Screwdriver
- Small Flat Blade (1/8" wide) type Screwdriver
- Amp-Clamp Current Sensor (if available)
- Digital Volt Meter (required for troubleshooting only)

Materials Required (not provided):

- Four 1/4" x 1-1/2" lag bolts and/or appropriate hardware for mounting the Control Unit
- 15 Amp single pole circuit breaker for the Control Unit's 120 VAC power supply (3-pole for 9388B3 versions or any version using the ES 1020 PLC Transmitter).
- Sufficient length of #14 AWG hookup wire to connect 120 volt power and ground from the circuit breaker panel to the Control Unit
- Sufficient conduit — #10 AWG, #12 AWG or #18 AWG wire (depending on load size and circuit type) and associated hardware to connect circuit breaker panel to Control Unit (if required)

Pre-Installation System Check List

Parts Check. Package should contain all parts listed*:

Qty	P/N	Description
1	FG9388B-xxxxxxA ¹	9388B Control Unit
2 or 3	See Chart 10.4 on page 48	Current Transformers ²
1	3620-7002	Warranty Registration Card
1	09388-94300A	9388B Technical Manual

¹Digits with "x" will vary depending on specific features of the controller as ordered.

² Current Transformers (CT's) are not included with the 9388B. They must be ordered separately, but will arrive with the unit. Choose the CT that's best appropriate for your application from Table 10.0 on page 45.

* Depending on your configuration, parts included may vary.

Contact your Energy Sentry® dealer if any parts are missing.

CAUTION **Ensure all circuits to be controlled are turned off at the appropriate breaker in the circuit breaker panel before proceeding with any wiring.**

Locating and Mounting the Relay Unit

The 9388B Control Unit is available either in a 18" x 12" x 4" NEMA 1 enclosure for indoor recessed mounting or a 12" X 10" X 4" NEMA 3R hinged-door enclosure for outdoor or indoor surface mounting. Typically this unit is mounted in an electrical room in close proximity to the incoming electrical service, the meter (if pulse input is used) and circuit breaker panel. Four screw holes (for 1/4" fasteners) are provided in each rear corner of the enclosure. Screws, lag bolts or other appropriate means may be used to mount the unit.

Remove the cover by unlatching the clasp on the NEMA 3R enclosure or loosening the screws on the NEMA 1 enclosure and open the cover. Remove the relay plate (chassis) from the enclosure by loosening the 1-4/20 hex nut at the top of the relay plate, then removing completely the hex nut at the bottom of the chassis.

Carefully slide the chassis out of the enclosure and set in a CLEAN and DRY location. Mount enclosure in an upright vertical position near the circuit breaker panel, service entrance and/or meter but no higher than 6' above the ground using four 1/4" lag bolts and/or appropriate mounting hardware. Care should be taken to clean all metal chips or other debris out of the enclosure when mounting is complete.

Connect the enclosure to the circuit breaker panel by means of appropriate conduit for the application. For pulse input and single-phase units, three #14AWG wires (120VAC hot, neutral and ground) are needed for the systems's power supply. For 3-phase units or units that contain a Wirelynx PLC transmitter (for both 120/208 Wye or 120/240 Delta connections), five #14AWG wires are needed as follows: three (3) hot (1 for each voltage phase), neutral, and ground. A separate conduit between the enclosure and the circuit breaker panel may be required, by electric code, for current transformer leads. Use the appropriate conduit to connect the circuit breaker panel or service entrance to the enclosure. Up to six (6) #18AWG (min) to #12AWG (max) wires will be necessary for these connections. Current transformers are supplied with 6' leads. If the unit can be mounted within the wire-feet available, no splices will be necessary.

Once enclosure mounting is complete, has been cleaned, is free of metal chips, and all conduits are in place, replace the 9388B chassis assembly and secure with the hex nuts provided.

Wiring the 120 VAC Power Supply to the Control Unit

For pulse or single-phase units that do not use a Wirelynx PLC, install a 15 amp, 120VAC single-pole circuit breaker. Mark this breaker "Energy Sentry 9388B".

Using the #14AWG wires previously run from the circuit breaker panel, connect the black supply (hot) wire to the black wire of the power transformer. Connect the white (neutral) wire to the white wire of the power transformer. Connect the green ground wire to the grounding clamp of the chassis marked "GND".

For all 3-phase units, as well as pulse or single-phase units that use a Wirelynx PLC, install a 15 amp, 120VAC three-pole circuit breaker. Mark this breaker "Energy Sentry 9388B". A 20 amp three-pole breaker may alternately be used, but in this case, wires must be #12AWG.

For **WYE**, use the #14AWG wires previously run from the circuit breaker panel, connect the three "hot" wire (black, red and blue for WYE or black, orange, and blue for DELTA) wires to the 9331A 3-phase adapter board. Connect the black wire of the unit's power transformer to the black wire (Phase A) of the 3-phase board's terminal #1. Connect the white (neutral) wire to the 9331A 3-phase adapter board's neutral terminal #4 and to the white wire of the power transformer. Connect the red phase wire (Phase B) to the 9331A 3-phase adapter board's terminal #2. Connect the blue phase wire (Phase C) to the 9331A 3-phase adapter board's terminal #3. Connect the green ground wire to the grounding clamp of the unit's chassis marked "GND". See the wiring diagram Figure 4.0 Also see Section 10 on 3-phase current transformer installation and wiring.

For **DELTA**, connect the high leg (orange) to the 9331's terminal #3. See Section 10 for 3-phase application details.

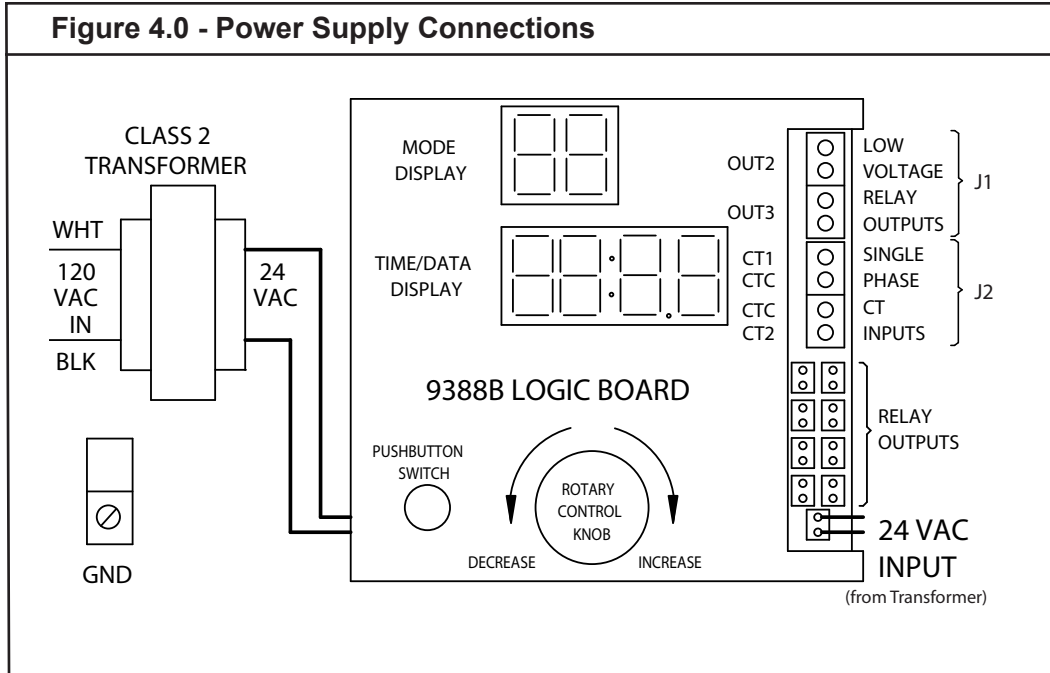

CAUTION Leave breaker off until installation is complete.

Installing and Wiring Current Transformers

For pulse input applications, proceed to the "Installing and Wiring the Pulse Input" section on page 14.

Single-phase 120/240VAC services

For single-phase services, one pair of current transformers is generally required. For solid CT's, disconnect the main power to the circuit breaker panel by removing the meter, opening a main disconnect switch or by turning off power at the utility's transformer. When power is off, install current transformers around main feeder cables after the meter, but before the main breaker(s) as shown in the wiring diagram in Figure 4.1. Current transformers should be installed in the same direction with both polarity marks facing either up or down. Make sure that no branch circuits or sub-panels are tapped off the mains before the current transformers. The current transformers **MUST** measure the total building load – the exact same load as the meter – for proper measurement.

For Split-Core CT's, power may be on, but extreme care should be used when placing the CT's around the conductors. Remove the pole-piece of the CT by removing the white nylon screws and pulling the pole-piece straight out away from the body of the CT to open it. Place the CT around the conductor and replace the pole-piece and the nylon screws. Care should be taken to make sure that the pole-piece is correctly oriented. It will only fit one way and is not reversible. If current transformers are installed while power is on, the black and white leads of each CT should be connected to J2 on the 9388B's board or, if necessary, shorted together with a wirenut for safety prior to mounting.

Run the black and white current transformer leads into controller via the conduit. Cut the black/white lead wires of each CT to a sufficient length, leaving about 6-8" extra for a service loop. The wires must be of sufficient length to connect to J2, the 4-position terminal strip on the right hand side of the 9388B Controller Board Assembly. (See Figure 4.0.) To the greatest extent possible, do not run leads next to high voltage (Class 1) wiring. Strip each conductor back 1/4" and connect black & white wires to 4 position terminal strip J2 as shown in Table 4.0.

Table 4.0 - Single Phase CT Connections

J2 Terminal #	J2 Terminal Name	Wire Color
1 (top)	CT1	White - from CT1
2	CTC	Black - from CT1
3	CTC	Black - from CT2
4 (bottom)	CT2	White - from CT2

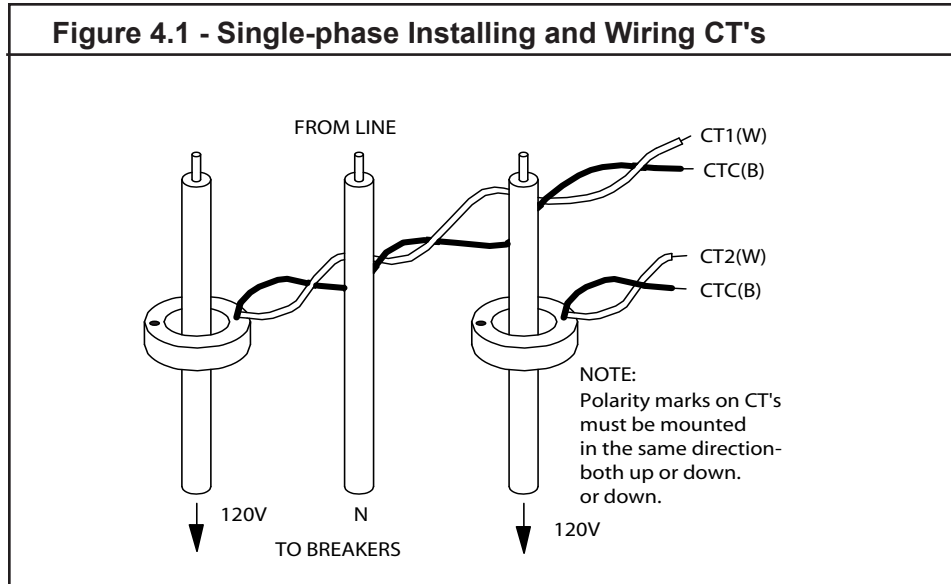

Three-phase 120/208 VAC WYE and 120/240 VAC DELTA Services

Three phase applications are similar to the single phase applications described above but use three CT's instead of two. Mount the three CT's in the circuit breaker panel or service entrance enclosure as necessary for the application, making sure that all power is monitored. All CT's must be mounted in the same direction and the polarity marks should all be pointing toward the meter. The CT's must monitor the exact same load as measured by the meter. No auxiliary panels or taps may come off the mains before the CT's. Refer to the Section 10 for 3-phase current transformer installation and wiring.

Installing and Wiring the Pulse Input

The 9388BP's pulse input gets its power monitoring information directly from the electric meter. The electric meter will normally be equipped with 3 output wires or terminals labeled K, Y and Z. Wire a #18/2 control cable from the meter back to the 9388BP's Control Unit as shown in Figure 4.2. If running this cable next to unshielded high voltage lines (120VAC or above), use shielded cable with the shield grounded on the electric meter end. Run one conductor from the K terminal (may be a red wire) to the CT1 terminal J2 of the 9388BP. Run the other conductor from the Y terminal (may be a yellow wire) to the CTC terminal J2 of the 9388BP. See Section 9 for more information on using the pulse input.

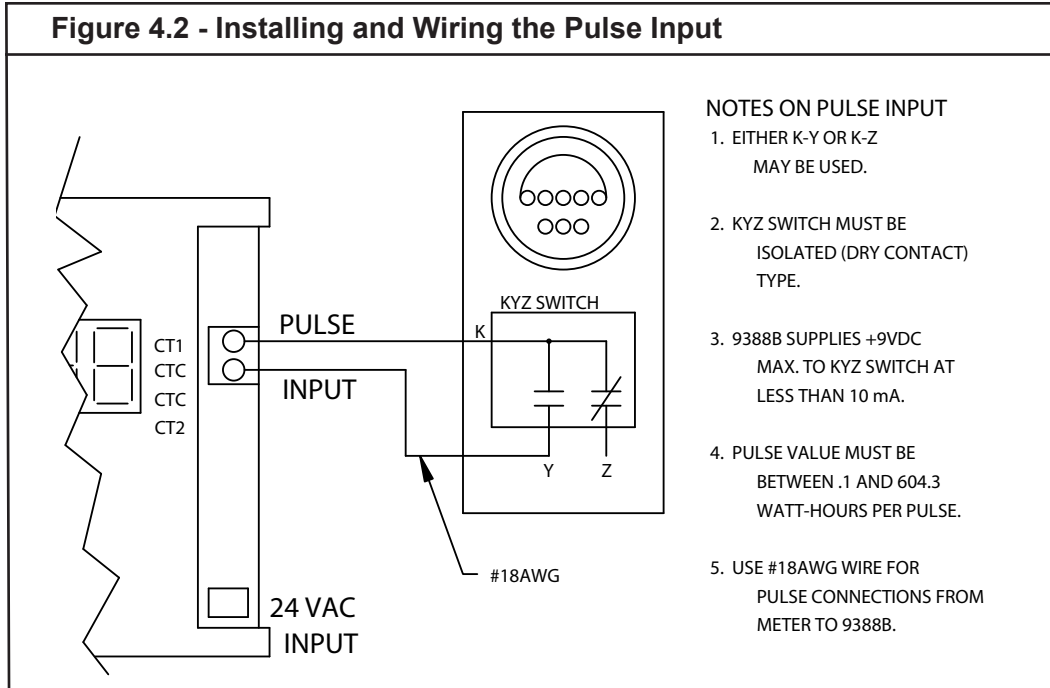

Line Voltage Control of Resistive Heat & Water Heater Circuits

Note: Single-phase water heaters are normally on a 30 Amp breaker and require #10 AWG wire. Heat circuits are normally on 20 amp circuit breakers and require #12 AWG wire.

Turn off all breakers for heat and water heater. Heat circuits and the water heater are connected to the breaker panel as shown in Figure 4.3. Both wires are connected to a 240 VAC double pole circuit breaker. The relay is inserted in series on one side of the load only as shown in Figure 4.4.

Remove either one of the two wires from the circuit breaker. Run two short lengths of #10 or #12 AWG (depending on load size) wire between the circuit breaker panel and the Relay Unit. Wire-nut the disconnected wire to one of the short lengths of wire that runs into the Control Unit. Wire-nut this length of wire to one lead of the relay's contact. With the other short length of the appropriately sized wire, wire-nut it to the other wire of the relay's contact. Connect the other end of this short length of wire back to the circuit breaker's terminal where the first wire was originally removed as shown in Figure 4.4.

Repeat this procedure for the remainder of the heat circuits and water heater(s).

Many times large commercial water heaters contain multiple heating elements. For example, an 18 KW water heater will contain three 6 KW elements. Use three power relays in this application, and connect each relay in series with one element. This allows control of the water heater in small (6 KW) blocks of demand.

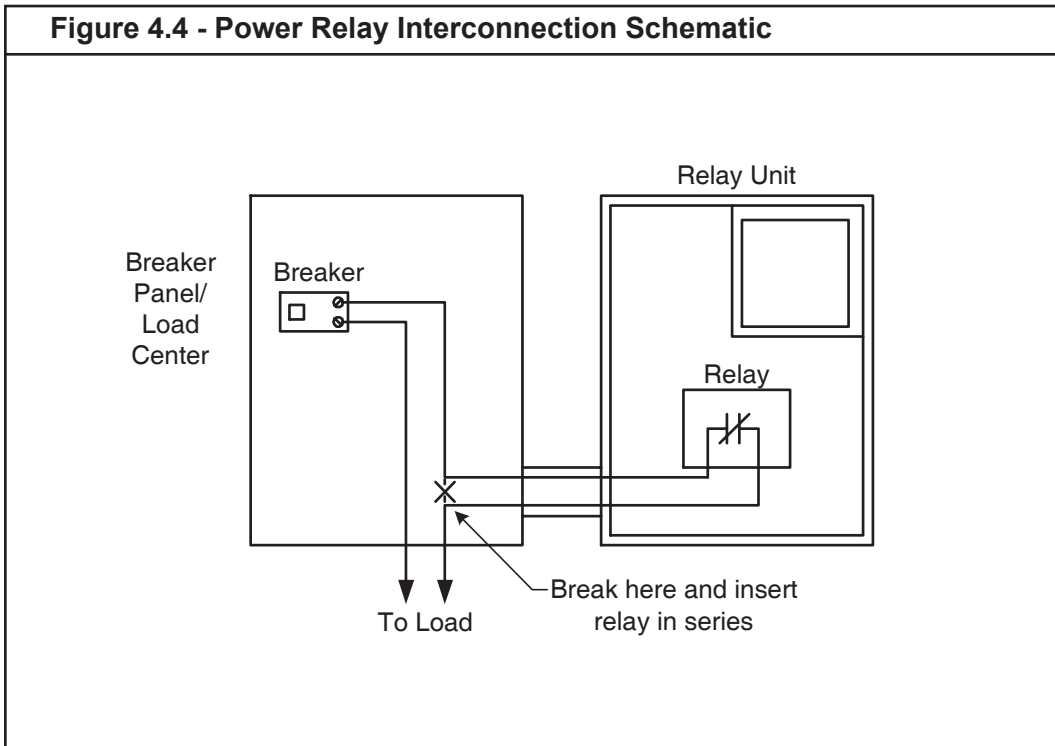
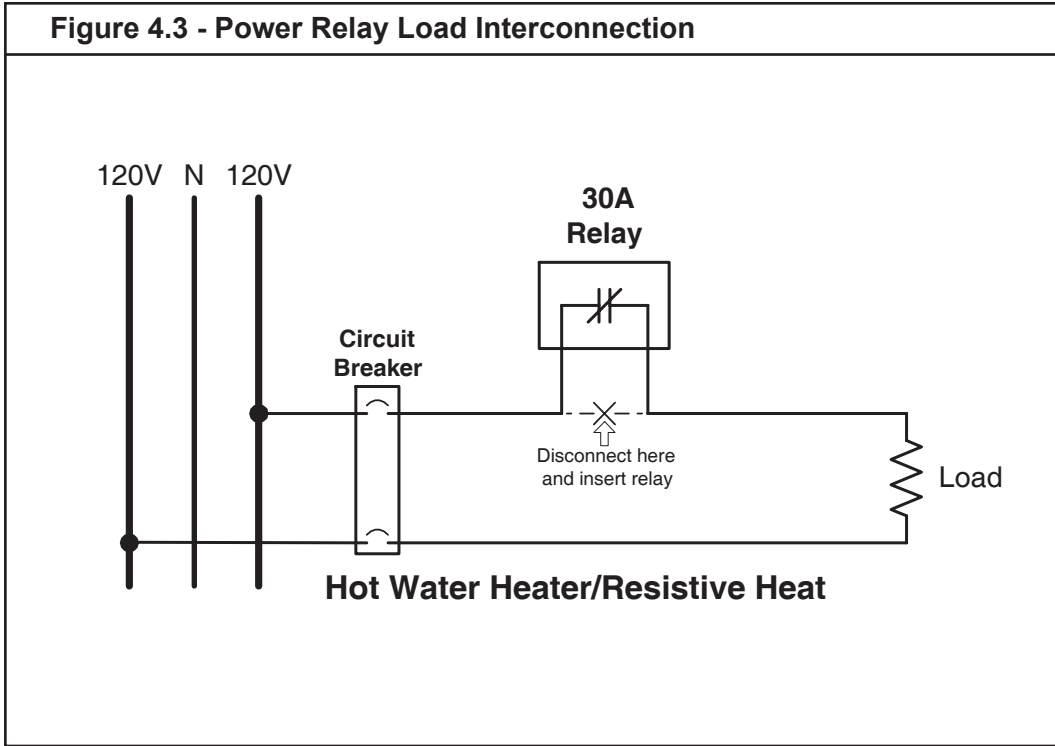

Low Voltage Control of Heat Pumps and Air Conditioners

Compressor Control

Turn off all breakers of loads that are going to be connected to the 9388B. Connecting air conditioners and/or heat pump compressors to the 9388B is accomplished by inserting a 3 amp pilot relay directly in series with the low-voltage 24 VAC thermostat control loop or by means of a low-voltage relay as shown in Figure 4.5. The relay is normally inserted in the compressor relay “Y” (usually yellow) wire. In heat pumps, this allows the compressor to be shed in both heating and cooling modes. The advantage with this method is that the fan continues to run and control may be less noticeable to building occupants. This may or may not be a problem depending on whether temperature can be maintained in the space with the blower fan running.

In the event that it is desirable to stop the blower fan when the compressor has been shed, a double-pole relay can be installed as shown in Figure 4.6, with one pole inserted in the compressor relay coil circuit and the other inserted into the blower fan relay coil circuit. This will prevent the blower from blowing air while the compressor is shed.

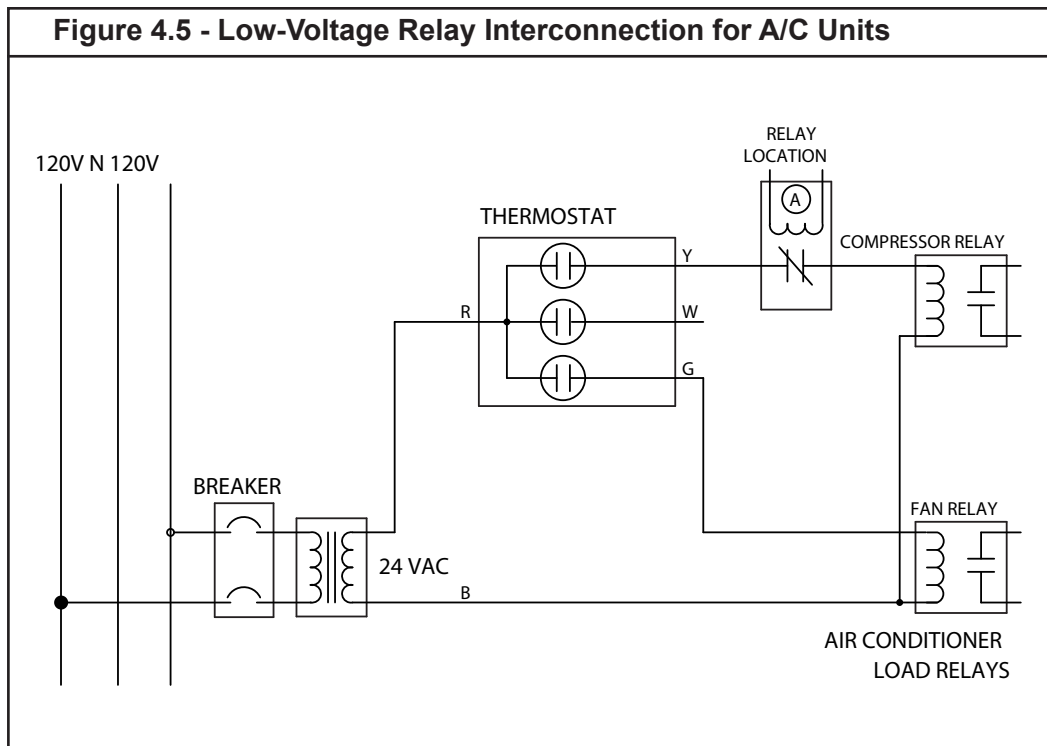

Controlling Air Handlers & Electric Furnaces

Heat Strip Control - One Heat Strip

It is strongly recommended that auxiliary electric strip heat in air handlers be controlled separately. If the air handler has one 5KW heat strip, the best method for controlling the heat strips is with an additional low-voltage remote relay inserted in the heat relay coil circuit of the thermostat loop, usually the white “W” wire. When the demand management system opens this relay, the heat strips are shed and compressor and fan circuits are unaffected and continue to operate. Figure 4.7 illustrates this method of wiring electric heat to the 9388B. In this scenario, the sequence of operation is

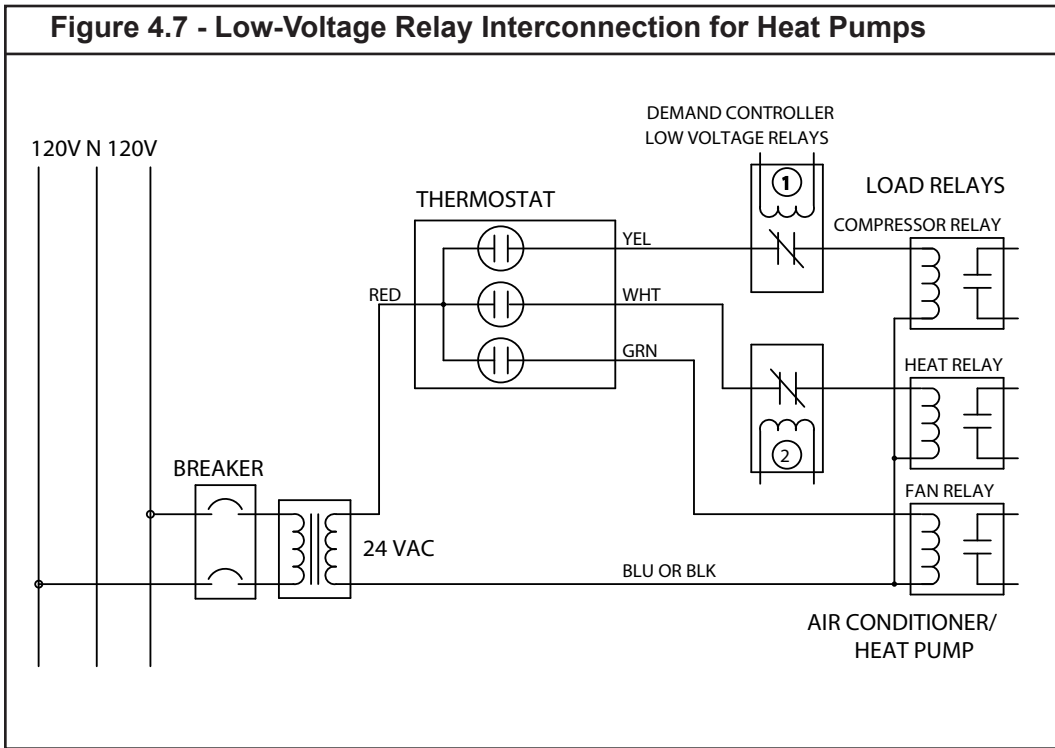
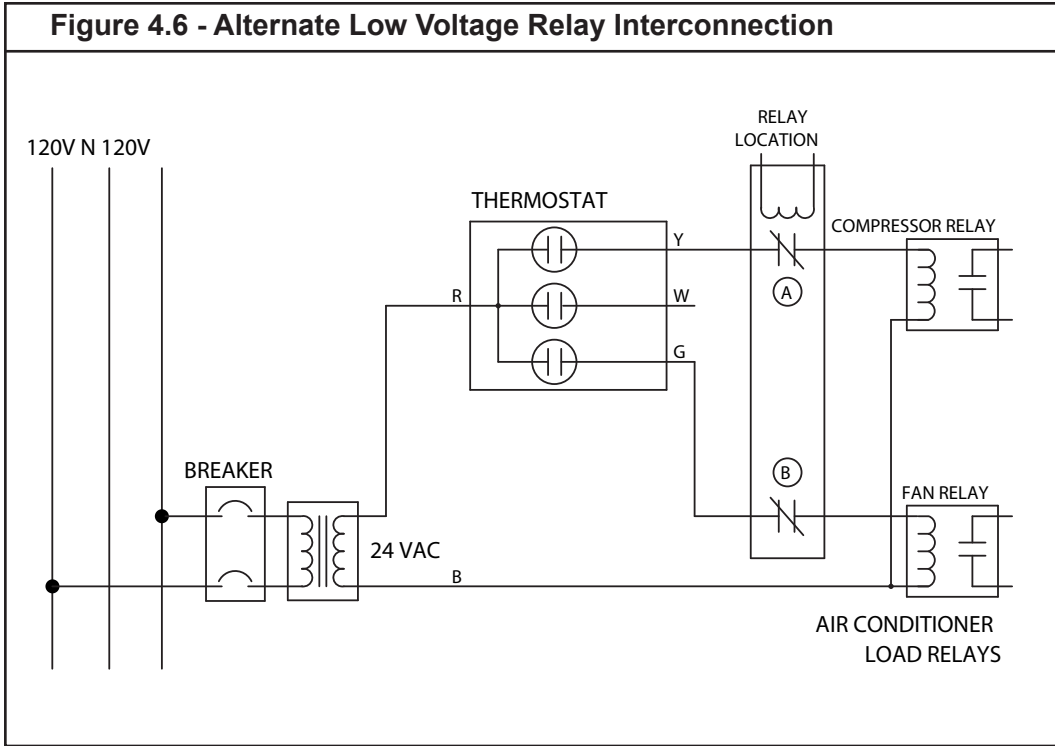

as follows: The control relay #2 is always opened before the compressor relay #1 since it has a lower priority than the compressor and has no minimum-on time. When the control relay #1 is opened, the compressor is shed. Once the demand management system begins restoring loads and the minimum-off time has elapsed for control relay #1, the relay will close, turning on the compressor. Finally, control relay #2 is restored, turning on the heat strips. If control relay #2 closes before control relay #1, the heat may or may not turn on depending whether a lockout of the strip heat exists in the heat pump's controls. If no internal lockout exists, the heat strips will come on. If this is the case, the blower fan should not be controlled (please refer back to Figure 4.6). This will prevent the unfavorable situation where the strip heats are turned on but the fan is shed. The advantage of this method of control is that it is usually easy to get to the low voltage thermostat wiring. The disadvantage is that it may take several seconds for the heat to actually turn off since heat strips are not directly controlled.

Note: *The color codes used in the figures above are generally accepted HVAC standard color codes. These may vary from manufacturer to manufacturer and from installation to installation. Check the wiring diagram carefully before wiring the demand management system to the heat pump and air handler. Make sure that the function is wired correctly regardless of the actual color of the wires.*

Heat Strip Control - Multiple Heat Strips

Generally, electric forced-air furnaces or air handling units' heat strips should be controlled independently, if possible. Electric furnaces or air handlers may have from one to five stages of heat that is controlled by what most manufacturers call a "sequencer". The sequencer usually uses a fixed priority type scheme to turn on and off these heat strips as required.

Heat strips may be controlled individually with remote power relays on the 240VAC line. For one or two stage electric furnaces or air handlers (each with three or four heat strips) connection to the demand management can be best accomplished by breaking these down into individual controlled circuits. This can be done by using a remote relay unit (BAC Model FG9291A) equipped with one 30 amp power relay per heat strip. The coils of these remote relays are connected to and controlled by the 9388B's outputs. Priorities of the heat stages are programmed the same relative priority levels as the sequencer. In this manner, 10KW heat stages (for example) can be broken down into two 5KW blocks of demand and controlled individually. This method of control is shown in Figure 4.8.

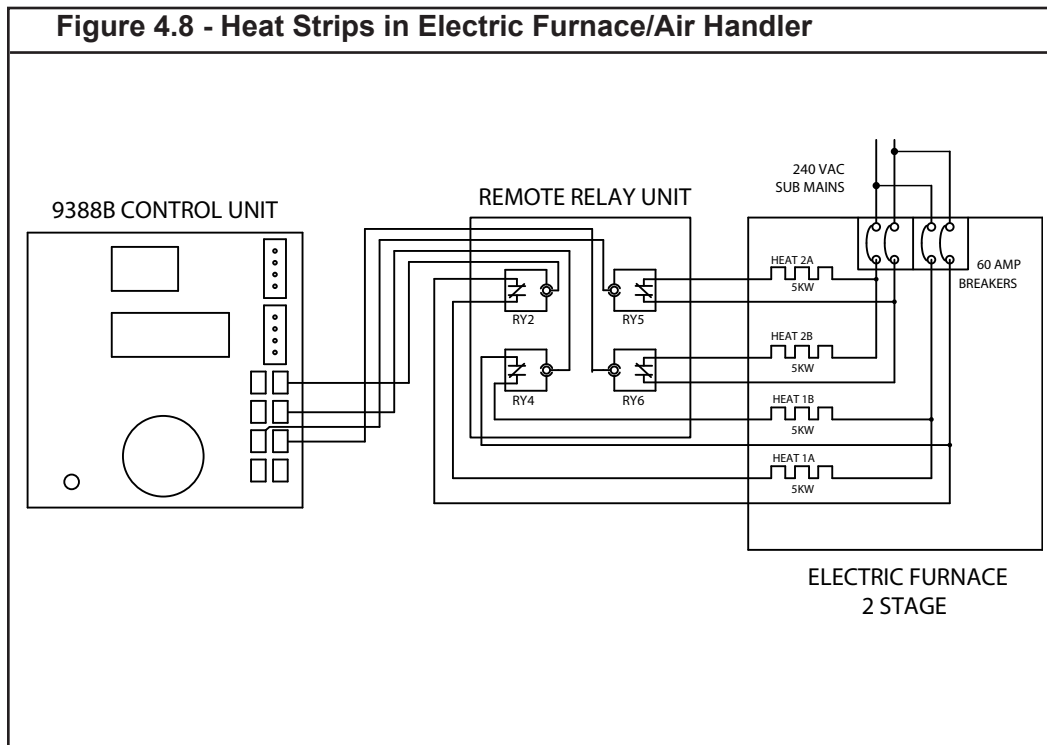

Section 5: System Operation

Your 9388B has been designed for ease of operation to provide efficient energy use under a demand limit. Please carefully read the following instructions concerning the operation of the 9388B as they will enable you to maximize efficient energy use and minimize your electric bill.

Your Energy Sentry Demand Management System may control as much as 40% to 80% of the total electrical load in your building. Except for process machinery and equipment, most of the uncontrolled loads are relatively small and do not create much of a demand. Because the demand limit is generally the only thing that you will need to change on an on-going basis, we'll talk about the demand limit and how to program it here. The rest of the settings to operate the system will be covered in "System Programming"

How the 9388B Works

The 9388B manages certain circuits by turning them on and off to keep peak demand below a limit that you have set. Circuits controlled by the 9388B usually include the air conditioners, heat pumps, electric strip heaters and water heaters. Loads that have some thermal storage capacity, won't impact the comfort and convenience of the building occupants, or that cause disruption in the ordinary course of business are the desired controllable loads for the 9388B.

In a typical commercial building, the winter morning routine may involve turning up some thermostats, turning on computers, office equipment and possibly some production or process machinery. Normally, operation of these loads causes a morning peak, such as that illustrated in Figure 5.0, that registers on the demand meter. In the summer, a typical routine might include the same office equipment and machinery being turned on, and later in the morning or early afternoon running air conditioning or cooling systems, as illustrated in Figure 5.1. In this case, these loads usually cause an afternoon peak. In both cases, the peak demand of these buildings is caused by the weather, specifically your use of electricity due to the season and the corresponding energy used for heating and cooling, as well as other normal non-weather related uses of electricity.

When an Energy Sentry 9388B is installed, it continuously monitors the instantaneous power used by your building and calculates the average demand. As the average demand begins to approach the demand limit that you've set, the

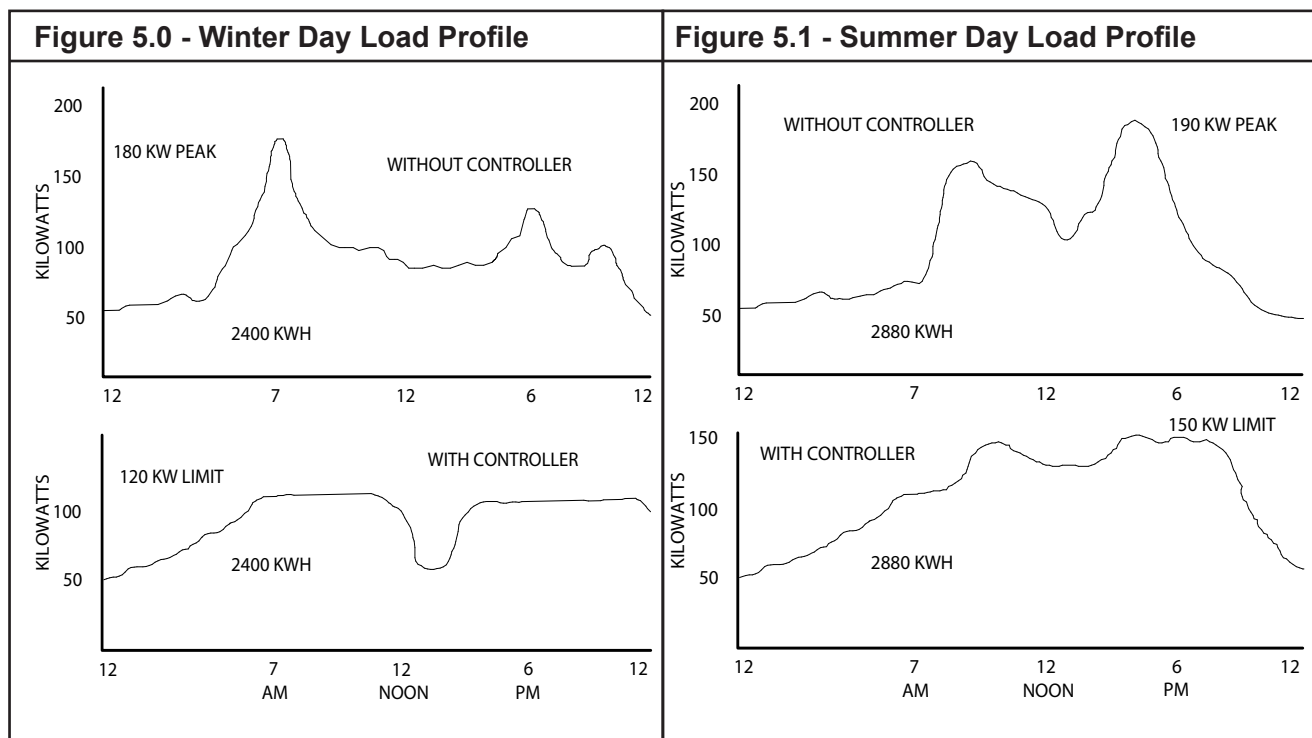

9388B decides when it must take action to control the demand to that level. At that point, the 9388B looks at all of the controlled loads and sheds the load with the lowest priority. It will continue to shed loads every 4 seconds until the building's instantaneous demand is brought below the demand limit.

When the 9388B determines that it is safe to restore controlled loads, it will turn on the highest priority load that is available to be restored. It will continue in 1-minute intervals to search for and turn on the next highest priority load available. It will continue to restore loads about once a minute until all loads are restored or until the average demand is in danger of exceeding the demand limit again. If your demand limit is set too low, the total of your uncontrolled loads may exceed the limit setting. When this happens, the 9388B will give an audible warning (if your system is equipped with the alarm option). This warning indicates that the demand limit is about to be exceeded. This means that you have at least a minute or two to turn off some of the uncontrolled loads to keep the meter from registering a higher KW than the demand limit. It also means that all of your controlled loads have been shed or that the controller cannot shed them due to minimum-on times timing out.

Important *Only your uncontrolled loads or controlled loads which are currently timing out a minimum-on time can initiate the over-limit alarm.*

The 9388B's User Interface

The 9388B contains a simple user interface consisting of three parts: The 6-digit display, the pushbutton switch and the control knob. All system settings are accessed, set and monitored using this user interface. Figure 5.2 on page 22 shows the location of the user interface parts.

First, the 6-digit display is divided into a top display of two digits and a bottom display of four digits (see Figure 5.3). The top display shows each system setting as a "mnemonic" (pronounced new-mon-ic), a two-digit code symbolizing the function of the setting. The bottom display shows either the value of that setting (as set by you) or the real-time readout of the data which the setting represents.

Display Saver

The 9388B is equipped with a "Display Saver" feature that turns off the display after 4 minutes if the pushbutton switch or the control knob have not been used. This decreases the power used by the 9388B and increases the life of the LED display. The colon will flash once per second to indicate that the system is operating properly and is in the display saver mode. To relight the display, momentarily press the pushbutton switch or turn the control knob one "click" in either direction. The 9388B is shipped with this setting enabled, but the Display Saver feature can be disabled so that the display stays on all the time. Go to the Display Saver (db) setting in the System Loop. Set this setting for "on" to enable the display saver feature. A setting of "oFF" will keep the display lit all the time.

Adjusting the 9388B

All programming adjustments are made using the pushbutton switch and control knob (see Figure 5.2). Refer to the complete list of settings in Appendix B. Turning the control knob clockwise changes the function in the display. The pushbutton switch is operated by pushing it horizontally away from you (not up, down, left or right). To make an adjustment in the Main Loop, turn the control knob until the desired function is displayed. Push and hold the pushbutton switch and immediately turn the control knob clockwise to increase the function value or counter-clockwise to decrease the function value. Release the pushbutton switch to save the value. See Section 6 for accessing and making adjustments to the System and Auto-Limit Loops.

CAUTION **While in the Main Loop, pressing the pushbutton switch and holding for 5 seconds will access the System Loop, if the control knob is not turned. While in the System Loop, pressing the pushbutton switch and holding for 5 seconds will access the Auto-Limit Loop. If this occurs by accident, release the pushbutton switch and rotate the control**

knob counterclockwise until “id” appears in the upper display, which means you are now back in the Main Loop.

CAUTION Many adjustments have the potential to increase your electric bill. If you are unsure about changing any settings, contact your authorized dealer before adjustments are made.

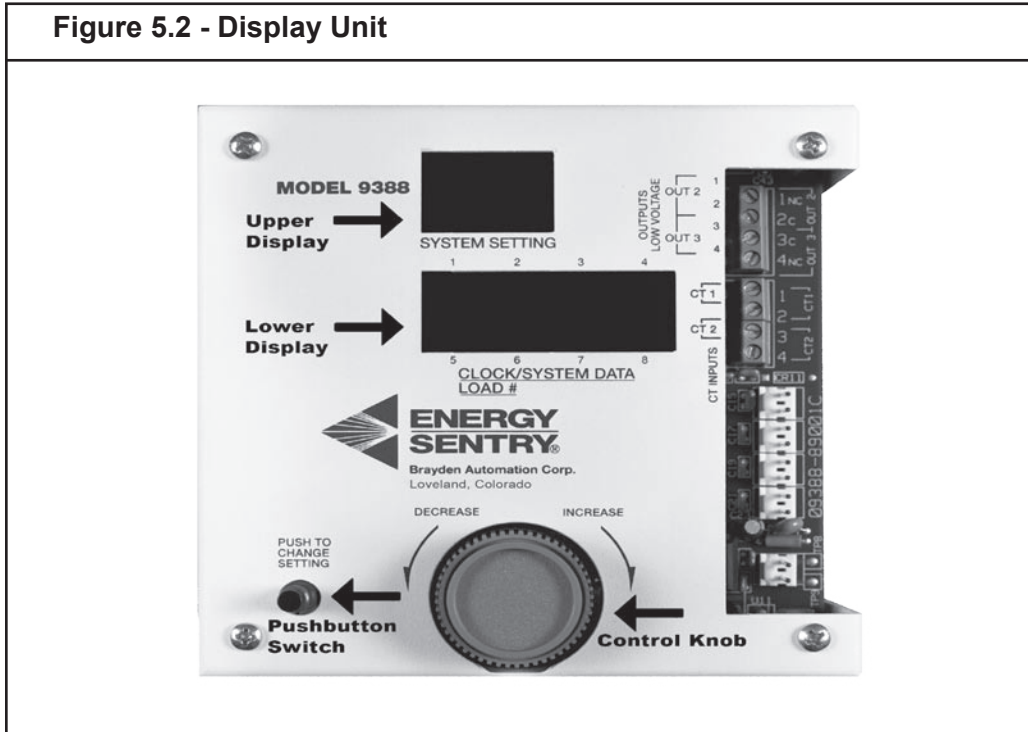

Display/Settings Sequence

The 9388B contains three display sequence “Loops”: the normal operation or “Main” Loop, the installation or “System” Loop and the “Auto-Limit” Loop. The Main Loop contains the following displays:

Display Order	Mnemonic	Function
→ ↓	id	Instantaneous Demand
↑ ↓	Ad	Average Demand
↑ ↓	PD	Peak Demand
↑ ↓	dL	Demand Limit
↑ ↓	LS	Load Status - Load 1-8 (Lower Bank)
↑ ↓	LU	Load Status - Loads 9-16 (Upper Bank)
↑ ←	CL	Clock

To step through these displays, turn the control knob to the right (clockwise) to move down through the list above to the proper display. Turning the control knob to the left (counter-clockwise) steps to the preceding display. To change the value in the display, hold down the pushbutton switch and within 5 seconds, turn the control knob until the desired value is reached on the display. Settings are automatically saved as soon as they are changed. An example of how these settings appear in the upper and lower displays is shown in Figure 5.3. The System Loop contains all system settings set when the controller was installed. Once set, these settings do not normally need to be changed. The listing of all system settings in the System Loop is shown in Appendix B.

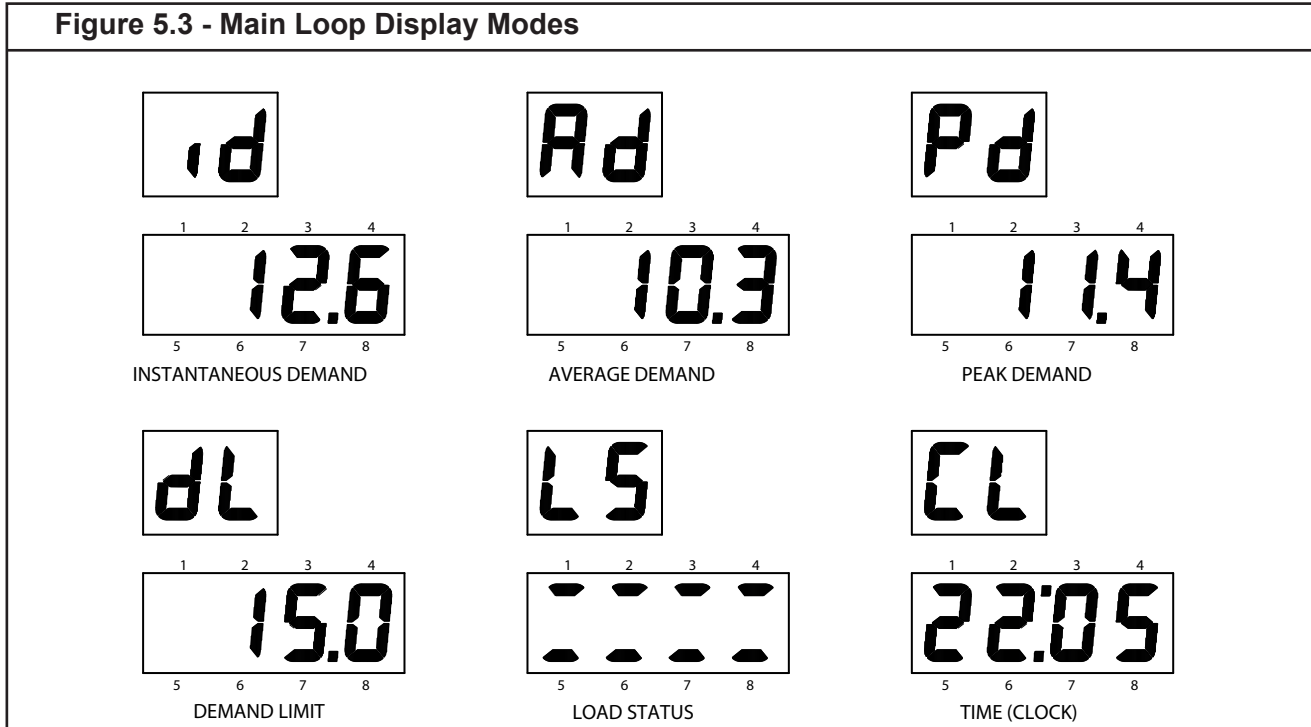

Setting the Demand Limit

There is no single demand setting that will be suitable for every application. The level of demand that is required to satisfy comfort, economy and convenience will vary, perhaps widely, with the uniqueness of each building, its loads, its occupants and the use profile. Refer to the Quick Start Guide in the front of this manual for instructions on how to change the demand limit.

Under normal conditions, a good starting demand limit is 80% of your last month's billing demand (if you're staying on your current electric rate). Read the demand on your last electric bill. Multiply this value by .8 or 80%. Reset the peak demand in the "Pd" mode. You will be able to tell within a day or two or possibly within a few hours whether your new demand limit is appropriate. Adjust as necessary to fit your savings or comfort/convenience goals. Each increment of demand is displayed in the "data" (lower) portion of the digital display. If you need more energy to maintain comfort, just increase the KW level by one increment. If, after a few hours, this is not enough, increase it by another increment again until you are comfortable.

If you are changing the type of electric rate that you're billed under, your starting demand may be dramatically less if your application is one which lends itself well to the new electric rate and demand control. Gradually adjust the demand limit up until the building reaches a balance of comfort, convenience, and controlled demand. It is important to remember that once the demand on the meter increases, it will not come down until it is reset by the meter reader each month. So it will not benefit you to lower your demand setting below what is already registered on the meter (See "Hints for Maximum Savings" on page 30). At a comfortable inside temperature, the KW demand level will be directly proportional to the heat loss or gain of the building. If your utility uses Interval Data (or Load Profile) meters, then there may be no actual physical "reset" of the meter's demand register. In this event, lower your demand limit a day or two before the meter reading date.

Setting Demand Limit Ranges

The 9388B has a demand limit setting range of up to 1000 KW in 1% increments of full scale. There are five full scale values: 50, 100, 200, 500 and 999.9 KW. This means that demand limits are changed in increments of .5, 1, 2, 5 and 10 KW respectively. Table 5.1 summarizes the demand limit ranges.

Full Scale (KW)	Minimum Demand Limit (KW)	Maximum Demand Limit (KW)	Demand Limit Increment (KW)
50	2	49.5	.5
100	4	99	1
200	8	198	2
500	20	495	5
1000	40	990	10

Demand Limit Automation

Auto-Limit Monthly Demand Limit Settings

The 9388B is equipped with the capability to automatically adjust set demand limits on a monthly, quarterly or seasonal basis. Up to 12 on-peak and off-peak demand limits and start dates may be set to automate your demand limit changes. The 9388B is shipped from the factory with this feature disabled. The 9388B will operate with the demand limit you have set in the “dL” mode until the Auto-Limit feature is enabled. Each start date, on-peak and off-peak demand limit represent a “setting group” and there are 12 setting groups that may be used. You may use all, some, one or none of these start dates and demand limits, depending on your particular needs. If you want to change your 9388B’s demand limit monthly to optimize your savings, set all 12 setting groups. If changing your demand limit quarterly provides the convenience you desire, simply set four setting groups. You can also use just one setting group to reset the demand limit to a lower level once a year, following the high use season, and use manual adjustments in the “dL” setting the rest of the year. In addition to the 12 setting groups, there is one additional setting called “nd” or number of days. This setting creates the “window” or target period. The “nd” setting determines the number of days before or after the target meter reading date that the demand limit will actually be changed. The demand limit is changed “nd” days after the target date if the demand limit is increasing. Conversely, if the demand limit is decreasing, the change will be implemented “nd” days before the target date. This allows for the variation of the actual meter reading date to target meter reading date and is necessary since the meter reader may or may not read your meter on the scheduled date. A five to six day window usually allows enough time for this variation.

How to Enable and Program Auto-Limit Settings

To access the Auto-Limit Loop, you must first be in the System Loop. You may be in any setting of this first level except the last setting “dr”. Press and hold the pushbutton switch for 5 seconds, just as you would to access system loop. “d1” will appear in the mode display. Press the pushbutton switch and turn the control knob to adjust the date. Release the pushbutton switch and turn the control knob one click clockwise. “L1” will appear in the display, indicating the demand limit for the on-peak period. Set the desired on-peak demand limit that corresponds to the date designated in the d1 setting by pushing the pushbutton switch and rotating the control knob in the direction of the desired demand limit. Release the pushbutton switch and again rotate the control knob one click. “o1” will appear in the display,

indicating the demand limit for the off-peak period. Set the desired off-peak demand limit that corresponds to the date designated in the d1 setting by pushing the pushbutton switch and rotating the control knob in the direction of the desired demand limit. Release the pushbutton switch and move to the next setting group by simply turning the control knob. Each successive “click” of the control knob will step you through the sequence listed in Appendix B. Following the last setting, one more “click” of the control knob will return you to “id”, the first setting of the Main Loop. Refer to the bottom of page 36 in the Programming section for the sequence of Auto-Limit settings.

Setting the Start Dates and Demand Limits

To optimize your savings by using the Auto-Limit feature, first review your electric bill or call your local utility to determine the meter reading date. Make sure that this is the date that electric service for the previous period ends and service for the next period begins, not the billing date which is usually different.

Your utility will be able to tell you the date your meter should be read. Weekends, holidays, unexpected delays or absences affect the actual date the meter is read. Each year, the start dates should be reviewed to confirm that the target meter reading dates are as previously expected and have not been changed. When you receive your utility bill, check to make sure that the meter was read during the target period, that is, the target date plus or minus the number of days programmed in the “nd” setting. You should notify your utility that the meter reading date is critical to you and that the meter should be read on the target date plus or minus “nd” days. Ask them to notify you in advance of any changes in the meter reading cycle that affect the meter reading date. The Number of Days setting (nd) should be set conservatively to make the change as close to the target date as possible, but with a high level of confidence that the meter will actually be read within the target period. Five to six days is usually adequate for utilities that read meters on a repeatable basis. Eight or nine days may be necessary for utilities who have a less structured and more irregular meter reading interval. Less than four days of offset time is usually inadequate because of weekends and holidays that fall on Friday or the following Monday.

Even if the utility can guarantee the meter reading date, an “nd” of 4 should still be used. If you use the Auto-Limit feature of the 9388B, keep in mind that the demand limit will change automatically at the programmed dates this year, next year and each year thereafter. They will change without warning and may not be appropriate or adequate for future year’s conditions, although weather is generally about the same from year to year. Even though the Energy Sentry 9388B’s Auto-Limit feature can make the job of adjusting your demand limit effortless, you need to review the target dates and demand limits periodically (no less than annually) to make sure they are right for you and consistent with your utility’s scheduled meter reading date. If you enable the Auto-Limit feature, the current demand limit currently in effect is shown in the “dL” setting. If you change the “dL” demand limit setting in the Main Loop to a new level while the Auto-Limit feature is enabled, it does not change the demand limit programmed in the Auto Limit Loop for the period the controller is currently in. The “new” demand limit serves as an override demand limit that is in effect only until the next scheduled demand limit change. For example, suppose the current date is August 12. The target dates you have set in the controller for d7 and d8 are July 15th and August 14th, respectively. You are currently in the seventh period and the L7 setting is 7.0 KW. The L8 setting is 8.5 KW. You have decided that 7.0 KW is not enough so you change the “dL” setting from 7.0 to 7.5 KW. Everything seems to be fine with 7.5 KW. Two days later, August 14th, is the meter reading date and the target date you have set in the d8 setting. The “nd” setting is 4 days. Therefore, on August 18th, the demand limit changes from 7.5 KW to 8.5 KW, the demand level set in L8 (August 14th plus 4 days of offset after, since the demand limit is increasing). Next year on July 15th, a demand limit of 7.0 KW will again be implemented.

Greater Convenience

Alternately, the Auto-Limit feature may be used to seasonally adjust demand limit with no consideration given to the exact meter reading date. To change the demand limit seasonally, simply set the desired starting date and demand limit. Set the “nd” to 1. This method will offer greater convenience and will simplify the use of Auto-Limit but will not yield the maximum savings which can be achieved. To disable the Auto-Limit feature of the 9388B, set all dates “d1” through “dC” to 0/0. Demand limits “L1” through “LC” are ignored when the start dates are set to 0/0, but will remain in memory if you decide to use them later.

Setting the Load Control Strategy and Load Shedding Sequence

The success of any demand control application is largely dependent on developing a load control strategy that fits the building, its heating and cooling systems and the use-patterns of the building's occupants. In general terms, developing a load control strategy is identifying the importance or “priority” of each controlled load relative to all other controlled loads and consequently, the sequence that each load will be shed and restored. A priority from 1 to 16 is assigned to each control point. Priority 1 is the highest (last shed, first restored) and priority 16 is the lowest (first shed, last restored). When the 9388B detects the average demand is increasing at a rate that will exceed the demand limit setting, the controller turns off or “sheds” the lowest priority load that is available. If necessary, additional loads will be shed to keep the average demand below the demand limit setting. Loads are shed according to the load control strategy selected. The three load control strategies are: 1.) Fixed Priority; 2.) Rotating; and 3.) Combination. These load control strategies are described below.

Fixed Priority Strategy

This strategy is also referred to as a “Priority Ladder” since each control point or load has a unique priority from 1 to 16. When the 9388B begins to shed loads, it sheds the Priority 16 load first and the Priority 15 load next followed by the Priority 14 load and so on until enough loads have been shed to reduce demand. When the 9388B begins to restore loads, it restores the Priority 1 load (or the highest priority load which has previously been shed) first, then the next highest priority load and so on until all loads have been restored or until the 9388B determines that no additional loads may be restored. The 9388B continuously works up and down the priority ladder shedding and restoring loads as necessary to maintain demand. This strategy works well when a predictable sequence of shedding or restoring is required. However, loads with the lower priorities receive less on time than loads with higher priorities. This may be satisfactory in applications where there are several low priority loads that can run anytime and are not time dependent to reduce demand.

Rotating Strategy

In this strategy, also called the “Ring” or “Round Robin” strategy, all controlled loads are assigned an equal priority, which turns loads off sequentially as required to maintain demand below the limit. The first load turned off is the first load restored at the beginning of each 1-minute interval. Subsequent loads are restored in the same order that they were shed. In this way, the off-time of rotating loads is shared equally among all loads. The 9388B continuously shifts around this ring as necessary to maintain demand. The advantage of this strategy is that the reduction in demand is shared by all loads and the desired comfort level is maintained in the building. This strategy works particularly well when there are a number of similar type loads, for example six air conditioners, which are all about the same relative priority to the building occupants.

Combination Strategies

Since the 9388B allows the user to program an independent priority for each control point, a virtually unlimited number of combination load control strategies can be selected. One or more groups of rotating loads, with or without fixed priority loads placed where desired are possible. One combination is shown in Table 5.2. In addition to these strategies, all circuits may be assigned minimum-on and -off times variable up to 20 minutes. This is a particularly attractive feature because heat pump and air conditioning compressors that require time-delay switching may be controlled under this strategy to best fit your application, use-pattern and operation of the business. The advantage of this control strategy is that it can be specifically tailored to any application.

Selecting the Load Control Strategy

The load shedding priority selected is based primarily on the type of heating and cooling equipment and the design of your building. If desired, the priorities may be easily changed. Tables 5.2 and 5.3 are typical examples.

Table 5.2 - All-Electric Small Office Building with Baseboard Heat
*Load Control Strategy: **Combination Fixed/Rotate***

Control Point #	Load Priority	Shedding Sequence	Load Description	Load Size in KW
1	1 (Highest)*		Office Heat	3.5 KW
2	1 (Highest)*		Reception Heat	1.5 KW
3	2	Second	Office Water Heater #1	5.5 KW
4	3 (Lowest)*		Office Heat	2.0 KW
5	3 (Lowest)*		Office Heat	3.0 KW
6	3 (Lowest)*		Conference Heat	2.0 KW
7	3 (Lowest)*		Warehouse Heat	5.0 KW
8	3 (Lowest)*		Shop Water Heater #2	4.5 KW

*Equal priority loads will rotate

Application Notes (Table 5.2)

- Office Heat and Reception Heat are the most critical loads in this application so they are set to Priority 1 and will rotate back and forth as necessary when all lower priority loads have been shed.
- Water Heater #1 will be a priority of 2 to keep it "charged". It will shed after all Priority 3's but before Priority 1's.
- All Priority 3 loads will rotate in a group. These five Priority 3 loads will contribute more to the demand management since they will be shed more than higher priority loads.

Table 5.3 - Small Commercial/Industrial Building with Heat Pumps/Air Conditioners
*Load Control Strategy: **Combination Fixed/Rotate Priority***

Control Point #	Load Priority	Shedding Sequence	Load Description	Load Size in KW
1	2	Fourth	Water Heater 1	4.5 KW
2	1 (Highest)*	Last	Compressor 1	3-7 KW
3	1 (Highest)*	Last	Compressor 2	3-8 KW
4	3*	Third	Strip Heat 1 Elec. Furnace	5.0 KW
5	4*	Second	Strip Heat 1 Elec. Furnace	5.0 KW
6	3*	Third	Strip Heat 2 Elec. Furnace	5.0 KW
7	4*	Second	Strip Heat 2 Elec. Furnace	5.0 KW
8	5 (Lowest)	First	Air Compressor	3.5 KW

*Equal priority loads will rotate

Note

Shedding sequence of rotating loads begins with the load which has been restored the longest. When all Priority 3 loads have been shed, the Priority 2 load is the next shed and finally the Priority 1 load will be shed last, if necessary.

Changing the Load Control Strategy

If you have added any large equipment to your facility or if your load requirements or load use patterns have changed since the last time load priorities were set, you may wish to change the 9388B's load control strategy. To change control point priorities, enter the System Loop and go to the priority setting to be changed. Simply adjust the priority up or down to the desired priority to make the priority higher or lower.

Load Lockout Timer - Priority 17

The 9388B is equipped with a load lockout timer which is helpful in shifting some of the building's demand and kilowatt-hour use to the off-peak times. During on-peak times, control points (loads) programmed with a Priority 17 will turn off or "lockout" loads connected to that control point. If the Off-Peak Limit (oL) is set to "oFF", then loads assigned Priority 17 will be enabled during off-peak times and are allowed to operate unrestricted. If the off-peak demand limit is set to another value besides "oFF", Priority 17 loads will be turned off (shed) first and turned on (restored) last, as necessary to maintain the off-peak demand limit.

Setting the Minimum-On and -Off Times

Each control point of the 9388B can be individually programmed with minimum-on and minimum-off times. These functions are designed for protection of motor loads such as compressors.

Minimum-On Times

Minimum-on times ensure that a load is not shed by the 9388B until the minimum-on time has elapsed. This is an efficiency strategy since it is of little value to turn on a load such as a compressor and turn it right back off without it having done any useful heating or cooling. Minimum-on times are typically set between 5 and 10 minutes, depending on the size of the compressor, with larger compressors having longer times. Minimum-on times should be used only with compressor loads and should be kept as short as possible since they restrict the 9388B's ability to control demand to a given setpoint. Minimum-on times above 8 minutes should be avoided, if possible.

Minimum-Off Times

Minimum-off times ensure that a load is left off ("locked out") and is not restored by demand control until the minimum-off time has elapsed. This is an equipment protection strategy for loads with a compressor since short cycling may damage a compressor. Minimum-off times are designed to give the head pressure of the refrigerant in the air conditioner or heat pump time to bleed off. Minimum-off times are typically set between 4 and 6 minutes, depending on the size of the compressor. Excessive minimum-off times will result in loads being kept off for extended periods of time and will ultimately impact the comfort and convenience of the building's occupants. If a heat pump or air conditioning compressor has off time delay protection internally it may not be necessary to use the minimum-off time feature of the 9388B.

Setting These Times

To set the minimum-on and -off times, enter the System Loop by holding down the pushbutton switch for five seconds, until the first setting, Temperature (dE), appears. Release switch. Turn the control knob until the minimum-on time setting (on) for the appropriate control point appears. The control point numbers appear sequentially from 1 up to the number set in the number of relays setting (nr). The "on" will be in the two digit mode display on the top. The control point number will be directly below the "on" near the left side of the lower display. The minimum-on time will be on the right side of the data display. To set the minimum-on time for a particular control point, set the mode display to that control point. Press the pushbutton switch and rotate the control knob until the desired minimum-on time is reached. The minimum-off times follow the minimum-on times in the System Loop and are sequential from 1 up to the number

set in the number of relays setting “nr”. The “oF” will be in the two digit mode display on the top. The control point number will be directly below the “oF” on the left side of the lower display. The minimum-off time will be on the right side of the data display. To set the minimum-off time for a particular control point, set the mode display to that control point. Press the pushbutton switch and rotate the control knob until the desired minimum-off time is reached. Release switch. Rotate control knob to the next setting to be changed or to the end of the System Loop. If no change is made within two minutes, the display will return back to the Main Display Loop.

Setting the Time-Of-Use (TOU) Functions

The 9388B is designed to work with either Regular (straight) Demand Rates or Time-of-Use Demand Rates. The TOU functions of the 9388B permit wide flexibility in applying the demand management system to all types of TOU Rates.

Regular Demand Rates

To disable all Time-of-Use functions and use the demand management system with 24/7 demand rates, set the Number of Seasons (nS) setting to zero (0). Alternately, this can be done by 1.) entering a date of 0/0 in each season’s start date (Sd, Ad, Ud, Fd); 2.) disabling all holiday settings (H1 through H9) and 3.) setting the weekend setting “SS” to “on.” These settings will cause the 9388B to be on-peak full time, regardless of the date, and will control to the demand limit set in the “dL” setting 24 hours a day, seven days a week.

Annual TOU Demand Rates

These rates typically have an on-peak and off-peak schedule which is the same year round. To program the 9388B for this type of rate, set the Number of Seasons setting (NS) to 1. Program the on-peak time(s) into the summer schedule settings S1 and S2. If two on-peak periods are used, program the second on-peak period into summer settings S3 and S4, otherwise set this S3 and S4 to 0/0. Set the summer start date to 1/1. If applicable, set the winter start date to 0/0. This causes the winter dates to be ignored and the summer schedule to run year round.

Seasonal Time-Of-Use Rates

These rates typically have two or more seasons per year with one or two on-peak periods per day. Generally, each season has a different schedule during the summer and winter seasons. Set the start and end times of each on-peak period for the appropriate season, as well as the date that each schedule goes into effect.

On-Peak (Full-Time Control) Seasons

If you desire to control 24 hours per day seven days a week, during one of the seasons of the year, this can be done by setting S1 through S4 (or A1 through A4, depending on the season desired) as follows:

Set S1 = S4 Set to any time (S1 and S4 must be the same).

Set S2 = S3 Set to any other time (S2 and S3 must be the same).

Off-Peak (No Control) Seasons

If you desire to not control at all during one of the seasons of the year, this can be done by setting S1 through S4 (or A1 through A4, depending on the season desired) as follows:

Set S1 = S2 Set to any time (S1 and S2 must be the same)

Set S3 = S4 Set to any other time (S3 and S4 must be the same)

Setting the Demand Control Algorithm "dC" Setting

The Energy Sentry 9388B Demand Management System includes several enhanced features that improve the 9388B's versatility and performance. One of these features which greatly enhances the user's comfort and control is the demand control algorithm (dC) selection setting. The user or installer can select one of five demand control algorithms. This allows the user or installer to select how aggressive the 9388B will be in controlling demand and how much risk of exceeding the demand limit the user is willing to take to increase the comfort and convenience in the building. The residential and small commercial-type of demand control situation is the worst case for managing loads: A.) only 3 or 4 loads to control; B.) high base loads with large percentage fluctuations; C.) loads that are a large percentage of the demand limit; D.) minimum-on times on the largest loads; and E.) users are intolerant of peaks over the demand limit. This situation calls for Algorithm #1.

The opposite situation would be: A.) many loads to control; B.) base load that is fairly constant; C.) base load(s) and all controlled loads are each a small percentage of the limit; D.) not all loads have minimum-on times; and E.) the user's savings are large, even if the peak demand exceeds the limit by 3% to 5%. This situation calls for Algorithm #5.

Algorithm Descriptions

1. This is the Standard, most conservative, demand control algorithm. It is designed to never exceed the demand limit, even under the worst case conditions (i.e. base load close to the limit, multiple large controlled loads with minimum-on times each exceeding the demand limit).
2. This is a Low-Risk demand control algorithm. It will maintain the average below the demand limit if there are no large, fast increases in the base load. The average will exceed the demand limit by a relatively small amount (if ever).
3. This is a Medium-Risk demand control algorithm. If the power used by the controlled loads is evenly distributed and the base load is fairly constant, then the average will not exceed the demand limit. Very large minimum-on time loads and large load fluctuations may cause the demand limit to be exceeded. Minimum-on time loads will be restored more rapidly with this algorithm (and Algorithms 4 and 5).
4. This is a High-Risk algorithm. The objective here is to allow more Kilowatt-hour (kWh) use within the current demand limit. The demand limit is treated as an absolute limit, but an effort is made to control very close to the limit. Consequently, the average will probably be above the limit every month, but by a small and repeatable amount. The trade-off is less control and more comfort especially in high air conditioning use months.
5. This is a Very High-Risk algorithm. The objective here is to provide the best KWh use under a given demand limit. The demand limit is treated as a guideline, not as an absolute limit. The peak average will almost certainly be above the limit every month, except in the most benign applications.

Hints For Maximum Savings

- When the demand limit is to be decreased, the setting should be decreased before your utility meter is read. You can check past bills to determine this date or call the utility company directly. When the demand limit setting is to be increased, the setting should be increased after your utility meter is read.
- You can help increase the effectiveness of your 9388B by trying to avoid turning on two or more major appliances or pieces of equipment at the same time, whenever possible. This will assist the controller not only in controlling demand but will increase the comfort level of your building.
- Additionally, shifting use of any loads possible to Off-Peak times will help to reduce your On-Peak energy usage charge.
- Use of setback thermostats may cause difficulty in getting your building heated or cooled quickly. For maximum comfort, set your thermostat to the desired temperature and leave it there to preserve the thermal storage of the building. For maximum energy savings, use setback thermostats, but extra time will be required to return the building to normal temperatures. For TOU rates, the building should

be returned to normal temperature before the start of the on-peak hours. Setback the temperature on weekends or other extended periods of time when the building is unoccupied.

- Excellent insulation in your building will help demand management significantly and again will assist in getting and keeping the thermal storage.
- High efficiency lighting will reduce the amount of heat that A/C systems have to get rid of. Change out magnetic ballasts and T-12 Lamps immediately! Replace with electronic ballasts and T-8 lamps. Use reflectors to decrease the number of lamps required.
- In most TOU Demand Rates, the on-peak demand and energy charges are substantially more costly per KW and KWh than the off-peak demand and energy charges. Finally, there is no substitute for keeping your heating, ventilating and air conditioning (HVAC) systems in good working order. Have your HVAC service company change filters regularly and checkout your systems annually. Equipment which is in “tip-top” operating condition will assist in controlling demand by not having to run as long as poorly maintained equipment for the same amount of heating or cooling. If changing out your compressor, buy the highest SEER rating available.

Section 6: Programming

Note: These programming instructions are based on 9388C V3.2 Software.

The 9388B is programmed by setting up to 145 different system operation parameters in the System and Auto-Limit Loops. The demand limit (dL), the clock (CL) and the reset peak (Pd) functions are programmed in the Main Loop. *It is the user's responsibility to maintain the correct time (clock setting), day-of-week, date, year, holiday dates and all other system settings which affect the controller's proper operation with Time-Of-Use (TOU) Demand Rates. It is recommended to check the time at least once a month.*

Explanation of Main Loop Display Modes

The following display modes are in the 9388B's Main Loop. To move through the modes, turn the knob clockwise to move down the list of modes in Appendix B or counter-clockwise to the mode above.

Instantaneous Demand (id)	The current demand presently being drawn by the electrical service of the building.
Average Demand (Ad)	The average demand that has accrued over the last 15, 30 or 60-minute interval, as determined by the Averaging Period (AP) set in System Loop. The averaging period selected should be the same as the averaging period of the utility's demand meter. The 9388B uses a continuous "sliding window" demand averaging method, not a resetting or block interval demand averaging method.
Peak Demand (Pd)	The peak demand is the highest rate of usage that has occurred in any demand interval during the billing period. The 9388B tracks the peak demand for you and displays it in the "Pd" mode. The level of the peak demand in the "Pd" mode should be approximately the same value that has been set on the electric meter and consequently, the demand that you will be billed for. To reset, set controller to "Pd" mode, press the pushbutton switch and simultaneously turn the knob one "click" counterclockwise. If you are in the on-peak mode, you will see the lower display go to zero, then go up to the current average demand.
On-Peak Demand Limit (dL)	The "dL" mode can display two separate pieces of information. First, the "dL" mode displays the current demand limit that is in effect. If the 9388B is currently in an on-peak time, then the on-peak demand limit will be displayed. If the 9388B is in an off-peak time, the off-peak demand limit will be displayed. While off-peak, the on-peak demand limit can be checked by simply pushing the pushbutton system switch. The display will show the on-peak demand limit while the pushbutton switch is depressed. Be careful not to hold the pushbutton switch down for longer than 4 seconds as the display mode will change to the System Loop. You can also change the on-peak demand limit while in the off-peak mode by pushing the pushbutton switch and rotating the control knob like normal. The only difference is that when you first push the pushbutton switch, the display will change from the off-peak demand limit (current in force) to the on-peak demand limit. The on-peak limit must be less than the off-peak limit for proper transitions from off-peak to on-peak periods. The "dL" setting is adjustable up to 990 KW, in 5 different full-scale ranges, depending on the Full Scale setting (FS) selected in the System Loop.
Load Status (LS)	This display mode shows the on/off status of control points 1 through 8. Loads which are enabled (or are not currently shed) have a lighted bar in the data display. Loads 1 through 4 are displayed on top from left to right. Loads 5 through 8 are displayed on the bottom row of the data display. When loads are shed, the bars are not lit. Only those control points enabled by the "nr" setting will be active.
Load Status (LU)	This display mode is the same as "LS" above, except that it shows the on/off status of loads 9 through 16, if enabled. Loads 9 through 12 are displayed on top from left to right. Loads 13 through 16 are displayed on the bottom row of the data display. When loads are shed, the bars are not lit. Only those control points enabled by the

“nr” setting will be active. This mode is displayed only if the number of loads (nr) is nine or greater.

Clock (CL) The current (military) time between midnight (0:00) and 11:59 PM (23:59) of the next night.

Explanation of System Loop Programming Modes

To enter the System Loop, press the pushbutton switch and hold for 5 seconds. The display will change from the current Main Loop display mode to the first setting of the System Loop programming mode, “dE.”

Temperature (dE)	The current temperature, in (dE)grees Fahrenheit, inside the controller’s enclosure. Used for factory calibration only.
Day of Week (do)	The current day of the week. 1=Sunday, 2=Monday, 3=Tuesday, 4=Wednesday, 5=Thursday, 6=Friday, 7=Saturday.
Date-Month & Day (dA)	The current month and day of the month. A settings range from 1/1 to 12/31.
Year (Yr)	The current year. Setting range from 1992 to 2090 is allowed.
Auto Daylight-Saving Adjust (dS)	Allows the controller to be programmed to automatically adjust the clock (CL) for daylight-saving time (DST). This mode can be set to use no DST, the old DST, or the new DST as implemented in 2007. Set to “1” for the old daylight-saving time dates (the first Sunday in April to go on DST and the last Sunday in October to go off DST), set to “2” for the new daylight-saving time dates (the second Sunday of March to go on DST, and the first Sunday in November to go off DST) and set to “0” (zero) to disable the Auto-DST adjust function.
Number of Seasons (nS)	This setting determines the number of different seasons as defined by your TOU Demand Rate. Zero to four seasons may be selected. If you are billed on a non-TOU rate, set to zero (0) for full-time 24/7 control. If you have set “nS” to 0, then the programming sequence skips to the “SS” setting and all subsequent seasonal timer settings will be disabled. If you are billed on an annual TOU Demand Rate, where the on-peak/off-peak schedule is the same time each day all year round, set nS=1. For standard two-season TOU Demand Rates, set nS=2. For 3 or 4 seasons, set “nS” accordingly.
Winter 1 On-Peak Time (A1)	The start time of the first daily peak period and when the on-peak demand limit is initiated. Setable from 0:00 to 23:59.
Winter 1 Off-Peak Time (A2)	The end time of the first daily peak period and when the off-peak demand limit is initiated. Setable from 0:00 to 23:59.
Winter 2 On-Peak Time (A3)	The start time of the second daily peak period and when the on-peak demand limit is initiated. Setable from 0:00 to 23:59.
Winter 2 Off-Peak Time (A4)	The end time of the second daily peak period and when the off-peak demand limit is initiated. Setable from 0:00 to 23:59.
Winter Start Date (Ad)	The date that the Winter rates go into effect, and the date the above Winter timers A1 through A4 are effective. A setting of 0/0 causes Winter timers A1 through A4 to be ignored.
Spring 1 On-Peak Time (U1)	The start time of the first daily peak period and when the on-peak demand limit is initiated. Setable from 0:00 to 23:59.
Spring 1 Off-Peak Time (U2)	The end time of the first daily peak period and when the off-peak demand limit is initiated. Setable from 0:00 to 23:59.

Spring 2 On-Peak Time (U3)	The start time of the second daily peak period and when the on-peak demand limit is initiated. Setable from 0:00 to 23:59.
Spring 2 Off-Peak Time (U4)	The end time of the second daily peak period and when the off-peak demand limit is initiated. Setable from 0:00 to 23:59.
Spring Start Date (Ud)	The date that the Spring rates go into effect, and the date the above Spring timers U1 through U4 are effective. A setting of 0/0 causes Spring timers U1 through U4 to be ignored.
Summer 1 On-Peak Time (S1)	The start time of the first daily peak period and when the on-peak demand limit is initiated. Setable from 0:00 to 23:59.
Summer 1 Off-Peak Time (S2)	The end time of the first daily peak period and when the off-peak demand limit is initiated. Setable from 0:00 to 23:59.
Summer 2 On-Peak Time (S3)	The start time of the second daily peak period and when the on-peak demand limit is initiated. Setable from 0:00 to 23:59.
Summer 2 Off-Peak Time (S4)	The end time of the second daily peak period and when the off-peak demand limit is initiated. Setable from 0:00 to 23:59.
Summer Start Date (Sd)	The date that the Summer rates go into effect, and the date the above Summer timers S1 through S4 are effective. A setting of 0/0 causes Summer timers S1 through S4 to be ignored.
Fall 1 On-Peak Time (F1)	The start time of the first daily peak period and when the on-peak demand limit is initiated. Setable from 0:00 to 23:59.
Fall 1 Off-Peak Time (F2)	The end time of the first daily peak period and when the off-peak demand limit is initiated. Setable from 0:00 to 23:59.
Fall 2 On-Peak Time (F3)	The start time of the second daily peak period and when the on-peak demand limit is initiated. Setable from 0:00 to 23:59.
Fall 2 Off-Peak Time (F4)	The end time of the second daily peak period and when the off-peak demand limit is initiated. Setable from 0:00 to 23:59.
Fall Start Date (Fd)	The date that the Fall rates go into effect, and the date the above Fall timers F1 through F4 are effective. A setting of 0/0 causes Fall timers F1 through F4 to be ignored.
Saturday/Sunday On/Off-Peak (SS)	Sets weekends to on-peak or off-peak depending on the local utility's rate. If your utility has on-peak periods on weekends, set to "on". If weekends are off-peak, as determined by your TOU rate, set this setting to "oFF".
Holiday X (Hx)	Where "x" is Holiday 1 through 9. There are two types of holidays. Holidays 1 through 4 are general purpose and are set by date (month and day of month) and can be in any order. The first three holidays are set to the defaults of New Year's Day (1/1), Fourth of July (7/4) and Christmas Day (12/25). These are the most common holidays that fall on the same <u>date</u> each year. Each January 1st, set the dates of any other date-specific holidays that the utility considers as off-peak. Holiday 4 is set to 0/0 and is unused as a default. Holidays 5 through 9 operate differently. They can be set to a specific date of 1/1 through 12/31 and used in the same matter as Holidays 1 through 4 above, or they can be used as holiday-specific holidays, by setting them either as "onP" or "oFFP". They are assigned specific holidays as follows:

Holiday 5 - President's Day (3rd Monday in February)
 Holiday 6 - Memorial Day (1st Monday in June)
 Holiday 7 - Labor Day (1st Monday in September)
 Holiday 8 - Thanksgiving Day (4th Thursday in November)
 Holiday 9 - Friday after Thanksgiving (4th Friday in November)

To enable these holidays as off-peak days, set them to "oFFP" and the 9388B treats these days as off-peak days and will not control on-peak demand levels on these days. If the utility company's rate does not recognize any of the holidays H5 through H9, set the unused holiday to "onP" for on-peak. The 9388B will treat the day as a normal on-peak day and continue to manage demand levels on these days. The default of H5-H9 is "onP".

Off-Peak Peak Demand (oP)	The highest average demand (Ad) that has occurred (since last reset) during the off-peak periods only. To reset, set controller to "oP" mode, press the pushbutton switch and turn control knob one "click" counterclockwise. It will drop to zero.
Off-Peak Limit (oL)	The demand limit during the time the controller is in an off-peak period. Adjustable in 1% increments of Full Scale (FS), or to "oFF". If your utility does not meter demand during off-peak periods, set this to "oFF", and the controller will not control demand during these periods. For proper controller operation, the off-peak demand limit should be greater than the on-peak demand limit. <u>The demand limit set in this setting will be displayed in the "dL" setting in the Main Loop only during off-peak periods.</u>
Maximum Instantaneous Demand Limit (HL)	This setting controls the highest instantaneous load that the 9388B will allow. This setting can be used in conjunction with generators, photovoltaic systems or other applications where there is a restriction on the maximum instantaneous demand that may be drawn. When the instantaneous demand exceeds the "HL" setting, the system will respond by shedding one or more loads within 4 seconds. The "HL" setting must be greater than the Demand Limit (dL) setting to operate properly. It is not recommended to use the "HL" setting in normal demand control applications. To disable this setting, set to "oFF" by turning the control knob clockwise to the maximum range of this setting.
Display Saver (db):	This setting enables and disables the Display Saver feature. To use display saver, set the setting to "on". When enabled, the display will turn off in 4 minutes if the control knob or pushbutton switch are not used. A colon will flash to let you know the system is operating. To "wake" the system, simply turn the control knob one "click" or press the pushbutton switch. To disable the Display Saver feature, set to "oFF". This will keep the display on all the time.
# of Relays Connected (nr)	This setting tells the controller how many relays are installed, starting from Control Point #1 and counting up to 16. This setting turns off unused control points. The number programmed into this setting should be equal to the number of relays used and all relays used should be on consecutive control points starting with #1. Only control points enabled at this setting will appear in subsequent settings for Priorities, Minimum-On Times and Minimum-Off Times.
Priority (Pr) (x)	The priority of each load relative to all other loads connected to the controller, where 1 is the highest priority and 16 is the lowest priority. Each control point (x) is adjustable from a priority of 1 to 17. The highest priority loads are shed last and restored first, while lowest priority loads are shed first and restored last. Loads connected to relays with a priority of 17 will be turned off during all on-peak periods. They will be restored only during off-peak periods, but can be shed by demand control if a real off-peak demand limit is set in the "oL" setting.

Minimum-On Times (on) (x)	This sets the 0 to 20 minute minimum-on time for each control point (x). Control points having a heat pump, air conditioner compressor or other motor load connected to it should have a minimum-on time programmed in of at least 6 minutes. Resistive loads should not have minimum-on times. Minimum-on times should be kept as short as possible and should not be used unless necessary because they restrict the controller's ability to control demand. <i>Use of minimum-on times may cause the meter's demand to exceed the set demand limit.</i>
Minimum-Off Time (oF) (x)	This sets the 0 to 20 minute minimum-off time for each control point (x). Control points having a heat pump or air conditioner compressor or other motor load connected to it should have a minimum-off time programmed in of at least 4 minutes. Resistive loads should not have minimum-off times.
Demand Control Algorithm Selection "dC"	Selects a demand control algorithms which defines the amount of risk the 9388B will take in controlling loads and still be able to control demand to the demand limit. Algorithm #1 is the most conservative and will try at all costs to maintain the demand limit. Algorithm #5 is the least conservative and uses the demand limit as a guideline rather than an absolute limit. While it gives greater comfort, it may also allow the peak demand to slightly exceed the demand limit. See Page 30 for a detailed description on this feature.
Averaging Period (AP)	This function sets the demand-averaging interval to 15-, 30- or 60-minutes. This should coincide with the averaging period of the utility's demand meter.
Demand Range (dr)	Sets the demand range and type of input to the controller. One of four input options are selected. These are: "40" (KW) for 200 Amp single-phase CT's; "80" (KW) for 400 Amp single-phase CT's; "3P" for 3-phase CT applications; or to "PULS" for pulse input. See page 24 for further information on how to set this setting with the "3P" and "PULS" models.
Full Scale (FS)	When the "dr" setting above is set for "3P" or "PULS", the full-scale setting appears. This setting selects the scaling of the demand limit settings of the 9388B. Since the demand limit is set in increments of 1% of the full scale chosen, the demand limit resolution is a function of this setting also. See page 43 for further information on this setting. This setting must be set to a Full Scale greater than the maximum instantaneous demand that will be monitored.
Pulse Constant (PC)	When the "PULS" setting is selected in the "dr" mode above, this setting follows the "FS" mode. This setting tells the controller how to interpret the pulses being received from the electric meter and consequently how to calculate instantaneous demand. See Section 9 for further information on how to program this setting.
Fast Instantaneous (Fi)	If this setting is set to "on", the instantaneous demand will be updated every second. If this setting is "oFF", the instantaneous demand reading will be updated every 8 seconds, and reflect the average instantaneous demand reading for the last 8 seconds. For a 30-minute averaging interval, the instantaneous reading will be updated every 16 seconds. For a 60-minute averaging interval, the instantaneous reading will be updated every 32 seconds. Using the Fi=oFF (slow) is not recommended unless the Fi=on (fast) performs poorly. The reason it may perform poorly would be due to pulses being received in bursts from an electric meter, rather than even, symmetrical pulses.

Explanation of Auto-Limit Display Modes

Period Start Date (dx)	The date on which the corresponding on-peak and off-peak demand limits "Lx" and "ox" are implemented where "x" is one of 12 periods from 1 through 9 followed by A, B and C. A date of 0/0 causes this setting to be ignored.
------------------------	-------------------------------------------------------------------------------------------------------------------------------------------------------------------------------------------------------------------------------

On-Peak Demand Limit (Lx)	The On-Peak demand limit, in KW, which is implemented on the date specified by the corresponding date setting “dx”. For example, when “d4” is set to April 17 and “L4” is set to 6KW, the on-peak demand limit will change to 6KW at midnight on April 17th. However, it will not actually be implemented until the start of the next On-Peak control period.
Off-Peak Demand Limit (ox)	The Off-Peak demand limit, in KW, which is implemented on the date specified by the corresponding date setting “dx”. For example, when “d4” is set to April 17 and “o4” is set to 18KW, the demand limit will change to 18KW at midnight on April 17th. It will be implemented immediately if it is an Off-Peak time at midnight (as it normally is with TOU rates), otherwise it will be implemented at the start of the next Off-Peak control period.
Number of Days Offset (nd):	The number of days before or after the target meter reading date when the demand limit will be changed, depending on whether the demand limit is being decreased or increased, respectively. The “nd” setting should be no less than 4, unless your meter reading dates are predictable.

Refer to page 24 for more information about the use of the Auto-Limit Feature.

Section 7: System Testing and Troubleshooting

Once the 9388B has been installed with all loads connected and programmed using the appropriate initial system settings, conduct the following test to ensure that power is being measured correctly and that all connected loads are shedding and restoring as expected. This test may take 30 to 60 minutes to thoroughly complete, so leave adequate time to do the test properly to ensure that everything is working correctly.

Prior to Test:

- a. Turn off all circuit breakers in the circuit breaker panel.
- b. Turn on thermostats/switches for all controlled loads.

Conduct Initial Operation Test:

- a. Ensure all circuit breakers in the circuit breaker panel are off.
- b. Turn on “9388B Demand Management System” circuit breaker. If you're using the 3-phase board 1020 PLC transmitter with the 9388B, multiple circuit breakers may be required to fully turn on power.
- c. All relay coils will energize within one second of power-up. You will hear all relays click. The “LS” (and “LU” if the number of relays “nr” is greater than 8) display modes in the Main Loop will indicate that all loads are shed with all load bars being unlit. Normally closed relays should open. Normally open relays (if any are used) should close. The top LED display will light up with the letters “id” displayed, indicating that all systems are operating properly. If unit fails to energize all relay coils off within one second, turn power off immediately. Check wiring and connections to make sure that the unit is wired properly. Try powering the unit up again as before. If problems still arise, call your Energy Sentry dealer or representative.
- d. Within eight seconds after power-up, if the 9388B is on-peak, the first relay (highest priority) should close and one relay, in the order of priority, should close every one minute thereafter (unless load is held off by a minimum-off time) until all relays are closed. Rotate the control knob to load status (LS or LU) display mode(s) to monitor the loads being restored. If the 9388B is off-peak, one relay will restore every 4 seconds starting with the highest numbered relay and ending with #1.

Conduct Power Off Test

- a. All relays should be closed. Check the load status (LS and LU) display mode. All light bars for enabled relays should be lit.
- b. Set the On-Peak demand limit (dL) to the lowest demand limit allowed on the 9388B Control Board according to the instructions in Section 3.
- c. Turn on a large uncontrolled load of a known KW size, greater than the demand limit. Verify power reading in the instantaneous demand (id) display mode by reading current on each phase with an amp clamp and applying the equation in Section 10. Leave all controlled loads off.
- d. Within 5 to 10 minutes, all relay coils should energize and turn off controlled load relays. This may be monitored using the “LS” or “LU” display modes. When 30- or 60-minute averaging time is selected, it may take several minutes longer for loads to shed, since the average KW demand is starting at zero.

- e. Turn off the uncontrolled load. Verify that the load's demand shown in the "id" display mode has gone back to the level shown (near 0) without the controlled load on. Raise demand limit (dL) to a higher than normal level, for example 1-1/2 to 2 times the normal expected demand limit. Within a few minutes, the controller will start to restore load relays. About every 1 minute thereafter, the controller should close or restore one relay. Use the "LS" and "LU" display modes to monitor relays restoring. This verifies that the unit is measuring power properly.
- f. Repeat Power Off Test if necessary to verify that turning on the large uncontrolled load with the demand limit set low caused the controller to shed loads and that turning the uncontrolled load off and setting the demand limit high allowed the relays to restore.

Conduct Power On Test

- a. Ensure all circuit breakers in the circuit breaker panel are off except for the 15-amp "9388B Demand Management System" circuit breaker. All thermostats must be calling for heating or cooling. Observe the Instantaneous Demand (id) display mode to be sure that little or no demand is being used. The only demand should be the power consumed by the demand management system unit and minimum lighting.
- b. Set the demand limit to a higher than normal level, for example 1-1/2 to 2 times the normal demand limit.
- c. This demand limit will allow all of the control points to be restored in about 16 minutes (1 minute per circuit unless held off by a minimum-off time). Listen for each relay to restore or observe the "LS" and "LU" display modes.
- d. Turn on each controlled load's circuit breaker one at a time (All thermostats should be calling for heating or cooling so you should hear or see each unit go on when you turn on the circuit breaker). Newer HVAC units may have an internal time delay which must elapse before the compressor turns on. The instantaneous demand (id) should increase the proper power reading as each load is turned on by the amount equal to the size of the load. This verifies that all relays are actually closed and each circuit is providing power to the load. Alternately, this can be verified with an Amp Clamp if available.
- e. Once all loads have been restored, assuming that it is in the on-peak period, immediately turn the Demand Limit setting (dL) to the normal, desired KW demand level. The system will begin shedding and restoring loads as necessary to maintain this demand limit. If it is during the off-peak time, loads will be restored as called for by the thermostats.

CAUTION **Do not leave controlled loads on any longer than necessary at this high demand limit as this may cause the electric meter to register a high demand peak.**

Note: *If minimum-on and -off times have been programmed into the unit, then loads controlled under these times will switch only when the appropriate time intervals have elapsed.*

- f. Restore all circuit breakers to the "on" position, and thermostats to their desired settings.
- g. The circuit breaker marked "9388B Demand Management System" should be left on always. It must be kept on continuously to maintain the demand in your building.

Service of Heating/Air Conditioning Systems, Water Heater and Other Controlled Equipment

Important *When technicians service any electrical equipment that is controlled by the system, they should be advised that you have a demand management system. They should also be warned not to disconnect*

the wiring to the system's relays or turn its power supply (circuit breaker) off. Otherwise, they may unknowingly disable your system which could result in a very high electric bill. If your system is turned off by service technicians, avoid using heating/cooling systems or other large electrical loads and turn off water heaters or other unnecessary loads at their circuit breakers. Damage to your 9388B may occur if service technicians disconnect the wiring between the 9388B and controlled loads.

The 9388B simply acts as another switch on all controlled equipment. It cannot cause damage or premature failure of the equipment when it is installed, and set and used correctly. Nor can it cause a higher electric bill than you would have had without a controller. When the power to the 9388B is off at the circuit breaker panel, power will still be available to all controlled loads, since each load is provided power through its own circuit breaker. Without power, the 9388B Demand Management System cannot control your building's demand. This is why the power must not be interrupted to the 9388B.

If your HVAC service technician has questions about the function of the 9388B, call your dealer or the factory for technical support.

If You Need Service

Your Energy Sentry Model 9388B has been carefully assembled and tested at the factory. Only components having a high degree of reliability and long life have been used in its manufacture. In the event that a failure does occur, your 9388B has been designed so all controlled loads will continue to function. The only difference is that there will be no demand control and high demand peaks can occur. If a malfunction should occur, you may turn off the 9388B at the circuit breaker labeled "9388B" or "Demand Management System", located in the circuit breaker panel. You may control your demand manually, if desired, to avoid unnecessary demand peaks as follows:

1. Heat or cool only those areas which are occupied by keeping the thermostat set only while you are in each room.
2. Avoid using major electrical appliances or equipment simultaneously. For example, do not use HVAC systems or your water heater at the same time. Manually control these by using thermostats and circuit breakers to avoid simultaneous operation.
3. You may monitor your highest demand peak on the utility meter to determine the effectiveness of manual control.
4. Since there are no user serviceable parts or components in the 9388B, refer all service to the installing electrician or authorized Energy Sentry Dealer or Distributor, as described in the Warranty.

Section 8: Wrap-Up

1. The 9388B Demand Management System should now be on and all breakers for loads controlled by the 9388B should also be on.
2. The 9388B should be set with the proper time-of-day, day-of-week, date and year.
3. The 9388B should be set with the proper system settings for your application. Air conditioner or heat pump compressors must have minimum-off times of at least 4 minutes programmed and minimum-on times of at least 5 minutes.
4. Relays in the 9388B's Control Unit or remote relays connected to the control unit should be turning loads on and off as necessary.
5. Replace the cover on the 9388B and on the circuit breaker panel.
6. Turn to Appendix C of this manual and record the following information in the spaces provided:
 - Unit Serial Number
 - Priority of each load
 - Load control strategy selected
 - Load assignments
 - Minimum-on/off times for all circuits, if enabled, otherwise write zero
 - Date of installation
 - Name and phone # of Dealer and/or installing electrical contractor
7. Complete Warranty Card and mail to Brayden Automation Corporation.
8. Leave the Owner's/Installation manual in a convenient location for future reference.
9. This concludes the installation of the 9388B. We value your feedback and hope that you will give us your comments on our products.

Note: Warranty card must be sent in for proper registration of unit and must include unit's serial number. Warranty is not valid unless warranty card has been received and unit has been registered.

Section 9: Using the Pulse Input

The Energy Sentry Model 9388BP is equipped with a Pulse Input which allows the power measurement to be done using the KYZ switch or pulse initiator in the electric meter. This method of power measurement is extremely accurate since the pulse output of the electric meter takes into account not only total load current, but variations in line voltage. In addition, use of a pulse meter may be less costly than installing current transformers.

Pulse Meter Connections

The 9388BP requires a “dry contact” KYZ switch and supplies a maximum of 12 VDC as the source voltage. The current through the KYZ switch is about 2 mA. The K and Y (or K and Z) contacts are used to connect to the 9388BP. Connect the Y terminal of the pulse output to the CT1 terminal of the 9388BP. Connect the K terminal of the meter to CT2 terminal of the 9388BP.

The meter’s KYZ switch must be “dry contact” meaning that there is no internal voltage source to the KYZ switch in the meter, and it must be electrically isolated from all other conductors in the meter. The 9388BP uses a two-wire (Form A) interface rather than the three-wire (Form C) interface. This is taken into account into the 9388BP’s software. Therefore, even though the 9388BP uses a two-wire KYZ interface, the three-wire pulse constant number or pulse value is used.

Pulse Constant (PC) Calculations

The Pulse Constant (PC) setting of the 9388BP is the number of watt-hours that each pulse represents. The utility metering industry defines a pulse as any change of state or transition of the KYZ switch in Form C mode. This differs from the classic definition of a pulse used in the controls and electronics industries. The local utility may supply you with the pulse constant of the meter. If the pulse constant is not readily available, it can be calculated if the following information is known:

Electromechanical or induction watt-hour meters that have a disk:

1. Kh – the watt-hour constant (Watt-Hours per Revolution) of the pulse meter.
2. CT – Current Transformer ratio (CT).
3. PT – Potential Transformer ratio (PT) if used. (Also sometimes called the VT ratio)
4. Number of Pulses per Revolution (PR) or the Revolutions per Pulse (RP) of the meter.

Calculating the CT x PT Ratio: Before plugging numbers in the formulas below to find the number of Watt- Hours per Pulse, the CT x PT ratio (or “M” for multiplier) must be calculated. The CT x PT ratio formula is as follows:

(Formula 1) $M = CT \times PT$

The multiplier, “M”, is actually the product of the CT ratio and PT ratio. For example, if your application has a meter that is driven by 600 Amp to 5 Amp Current Transformers and has a 2.4 to 1 potential transformer, M is calculated as follows:

$$M = \frac{600}{5} \times \frac{2.4}{1} \text{ or } = 120 \times 2.4 = 288$$

If potential transformers are not used, then $M =$ the ratio of the CT’s only. In the above case, M would be 120. If neither the CT’s or PT’s are used, then that means that you have a self-contained meter and $M = 1$. The multiplier found on the customer’s bill should be the same as the multiplier calculated here.

Note: The CT x PT Ratio or Multiplier is also called the Transformer Factor.

Calculating the Pulse Constant (Watt-hours per Pulse)

The Pulse Constant can be calculated two different ways depending on whether the meter expresses pulse frequency in “Pulses per Revolution” or “Revolutions per Pulse”.

- Calculations for Pulses/Revolution (PR): Pulses per Revolution (PR) is merely the number of holes in the meter or the number of Transitions per Revolution that the KYZ pulse switches. Normally, meters have 2, 4, 5, 6, or 12 holes (or Pulses) per Revolution.
- Calculations for Revolutions per Pulse (RP): Revolutions per Pulse is usually used on the newer PDR’s (Programmable Demand Register) or Pulse Meters. Typically, these can be programmed from between .1 to 10 Revolutions per Pulse.

Watt-Hour/Pulse Formulas

The following two formulas can be used depending on which information you have available:

- (Formula 2) $\text{Watt-hours/Pulse} = \frac{\text{Kh} \times \text{M}}{\text{Pulses/Revolution}}$
- (Formula 3) $\text{Watt-hours/Pulse} = (\text{Kh} \times \text{M}) \times (\text{Revolutions/Pulse})$

Solid State Meters

Most solid state meters have greatly simplified the pulse constant calculation by making it an independent setting in the meter. This value is known as “Ke” and is generally expressed in Kilowatt-hours per pulse.

If the Ke value is something like .001 on a relatively small customer, then you know that it is Kwh’s. Multiply this value by 1000 to convert to watt-hours (1 wh in this case) and multiply by the Transformer Factor (Multiplier) of the metering set up. Let’s say that this application used 400A to 5A CT’s, a ratio of 80 but no PT’s. The multiplier would be 80 and when multiplied by the Ke value of 1 wh/p, the pulse constant entered into the unit would be 80.

The 9388BP can accept a pulse constant (PC) of .1 to 604.3 watt-hours/pulse, in .1 wh increments. The 9388BP, used directly with a pulse output electric meter, is programmed for the same value as the pulse output of the meter. For example, if the meter has a pulse output of 10 wh/pulse, the 9388BP’s Pulse Constant (PC) value should be set for 10.0 wh/pulse. If the pulse output of the electric meter is expressed in Kilowatt-hour’s, rather than watt-hours, be sure to multiply by 1000 to convert the kilowatt-hours to watt-hours. If the 9388BP is used with a watt-hour transducer which has a pulse output, the PC value is set for half the watt-hour value of the watt-hour transducer. This is due to the difference in definitions of a pulse. For example, if the watt-hour transducer has an output of 40 watt-hours/pulse, the equivalent Form C Pulse Constant (PC) value should be 20.0 wh/pulse. Check with watt-hour transducer manufacturer to verify actual output value. Most watt-hour transducer manufacturers only offer a two-wire (Form A) output.

Utilities typically use a standard watt-hour per pulse value on meters within a particular size range. Generally, the Pulse Constant (PC) value should be kept as low as possible, as long as the pulse rate does not exceed about 10 transitions per second at maximum instantaneous demand. Try to stay in the range of 10 to 100 watt-hours/pulse, if possible, but this is strictly a function of the meter Pulses per Revolution and the size of the electrical service.

Setting the Full Scale and Pulse Constant

To set the Pulse Constant, enter the System Loop by pressing the pushbutton switch for five seconds, until the first setting “dE” appears. Release the switch. Turn the control knob to the Demand Range setting (dr) and make sure that it is set for “PULS”. This tells the 9388B Demand Management System that it is looking for a pulse input rather than

an analog or CT input. Turn the control knob one “click” clockwise to the Full Scale (FS) setting. Adjust the full scale to the next highest setting above the highest instantaneous you expect. To change the full scale, press the pushbutton switch and rotate the control knob clockwise or counter-clockwise until the desired setting is reached. Release the switch. Turn the control knob one more “click” clockwise to the Pulse Constant (PC) setting. Adjust the pulse constant to the correct number of watt-hours per pulse as calculated above, by pressing the pushbutton switch and rotating the control knob clockwise or counter-clockwise until the desired pulse constant setting is reached. Release the switch. The setting is automatically saved when you release the switch.

Using the Fast Instantaneous Mode

Most electric meters equipped with pulse initiators (KYZ switch) send out pulses in a symmetrical form, where the high and low time periods are roughly equal for any complete cycle. The 9388BP has no problem reading this type of pulse output up to about 10 pulses per second. However, some electronic meters send out pulses in bursts or packets once a predetermined number of watt-hours has accrued. For example, lets say the meter is pre-programmed to send out pulses when 1 KWh has accrued, and that each pulse is 100 watt-hours. When 1 KWh has been used, the electric meter will send out 10 very rapid, short duration pulses. Even though the number of pulses is correct, in terms of total energy used, it gives an erroneous demand reading of 2 to 10 times what the real instantaneous demand is. Consequently, it leads to poor control in a building equipped with this kind of meter.

When this kind of electric meter is installed in a building, or when the instantaneous bounces around too much, the Fast Instantaneous setting (Fi) should be set to "oFF". This filters out rapid changes in the instantaneous demand. This keeps the system from overreacting and shedding loads when it is not necessary. When the slow instantaneous is enabled, the Instantaneous Demand (id) will update every 8 seconds for an Averaging Period (AP) of 15 minutes. The update time will be 16 seconds and 32 seconds for averaging periods of 30 and 60 minutes, respectively. The Instantaneous Demand (id) is rounded to the nearest 1% of full scale, thus losing some of the resolution of the instantaneous display. This normally does not affect the Average Demand (Ad) reading.

Troubleshooting

Problems do arise when:

1. The wh/p value of the meter is too high and thus incoming pulses are too slow. This causes the 9388BP to control less favorably than if the pulse values were smaller and thus faster. Have the utility program the Ke value to a smaller value. That will make the pulses occur at a higher rate.
2. PC value is more than 604.3 wh/pulse for the 9388B. Have the utility reprogram the meter's pulse value.
3. Pulses to the 9388BP exceed 10 transitions/second, the wh/p value of meter is too low. Have the utility reprogram the pulse value of the meter.

Section 10: Using the 3-Phase Input & the 9331A Power Adapter

If your Energy Sentry Model 9388B Demand Management System is equipped with the 9331A 3-phase Power Adapter printed circuit board assembly (PCBA), the instructions in this section will assist you in installing and setting the system for proper operation. **Read these instructions carefully.**

Introduction

The 9331A 3-phase adapter board is available in two general types, one for 120/208VAC WYE services (P/N 09331-6900XA) and the other for 120/240 VAC DELTA services (P/N 9331-6910XA). The “X” designates different versions for different size current transformers. There are three versions of each of these two models depending on current transformers used. The current transformers ordered with your 9388B3 will determine the specific versions of the 9331A 3-phase Adapter Board (see Tables 10.1 and 10.2). These two versions of boards are not interchangeable and must be configured at the factory. Check the list of current transformers in Table 10.0 and select the model most appropriate for your application. Make sure that this 3-phase board is compatible with the current transformers selected.

Your Energy Sentry Demand Management System must be a Model 9388B3 to use the 9331A. That is, your 9388B3 unit’s main controller PCBA must be configured for a three-phase input and must be equipped with “C” version firmware. If you’re not sure or can’t tell, call the factory for help or simply remove the white logic cover which covers the 9388B3’s microcomputer PCBA and read the label on the EPROM just under the lower left-hand corner of the display board. The label should read “9388C Ver 3.2”. The “C” denotes commercial. This firmware (EPROM with the 9388C’s program) allows the 9388B3 to read power from the 9331A board.

Table 10.0 - Common CT Sizes

Part Number	CT Size	ID"	CT Ratio	CT Type
8420-3028	200A (Std)	1.35"	1000:1	Solid
8420-3029 ¹	400A (Lg)	2.25"	2000:1	Solid
8420-3030	400A (X-Lg)	3.5"	2000:1	Solid
8420-3031 ²	800A (X-Lg)	3.5"	4000:1	Solid
8420-3039	200A (Std)	1.25"	1000:1	Split
8420-3040	400A (X-Lg)	2.5" sq.	2000:1	Split
8420-3041	400A (Lg)	1.75"	2000:1	Split
8420-3042 ²	800A (X-Lg)	4.0" sq.	4000:1	Split
8420-3043	200A (Sm)	.75" sq.	1000:1	Split

²special order

¹Unless you specifically requested a special version of the 9331A PCBA and CT’s, you have will the standard configuration.

²Special order only

Table 10.1 - Settings for WYE Configurations

9331A P/N	CT Ratio/(Size)	Full Scale Setting
09331-69001A*	1000:1T (200A)	50KW
09331-69002A	1000:1T (200A)	100KW
09331-69001A*	2000:1T(400A)	100KW
09331-69002A	2000:1T (400A)	200KW
09331-69001A*	4000:1T (800A)	200KW
09331-69003A	4000:1T (800A)	500KW

*standard Wye configuration

Table 10.2 - Settings for DELTA Configurations

9331A P/N	CT Ratio/(Size)	Full Scale Setting
09331-69101A*	1000:1T (200A)	50KW
09331-69102A	1000:1T (200A)	100KW
09331-69101A*	2000:1T(400A)	100KW
09331-69102A	2000:1T (400A)	200KW
09331-69101A*	4000:1T (800A)	200KW
09331-69103A	4000:1T (800A)	500KW

*standard Delta configurations

Installation

Skip this section if the 9331A Board is already installed. If the 9331A board is not yet installed, it mounts under the right-hand half of the 9388B3 Main Control Board assembly. Make sure that ALL power in the unit is turned off. Remove the logic cover by removing the four 6-32 X 1/2" screws in the four corners. Gently slide the logic cover to the left slightly so that the phone jack on the left side of the logic cover comes out of its mounting hole. Then gently pull the logic cover up (toward you) away from the 9388B3 PCBA. Next remove the four 1" hex standoffs in the four corners of the 9388B3's logic board. Disconnect the yellow 24VAC power leads in the lower right-hand corner and any relay coils connected to outputs P1-P8 and any other wires connected to J1 or J2 above the relay outputs. The 9388B3 logic board may have a 26 conductor ribbon cable coming off the left-hand side of the PCBA, dropping down to a 1020A Powerline Carrier Transmitter PCBA. Remove the ribbon cable from the bottom board by pulling the ribbon cable gently up towards you. Set the 9388B3 PCBA aside somewhere where it will keep clean and free from metal chips, static discharges, dirt, etc. If possible, place it in a anti-static plastic bag while you're mounting the 9331A.

Mounting the 9331 in a 9388B3

The 9388B3 board is normally mounted on four 1" standoffs. If this is the case, remove all four of these standoffs and discard. If the standoffs attached to the relay plate are 1-1/2" long, leave the two on the left-hand side and remove the two on the right-hand side.

The 9331A is supplied with three 7/16" standoffs and two 1-1/2" standoffs and five KEP nuts. The three 7/16's standoffs are intended to mount in a triangle configuration as follows: two in the right-hand mounting holes for the board, and the third in the vertically centered hole near the center of the PCBA mounting area. Screw these standoffs into place on the relay plate using the 6-32 KEP nuts (hex nuts with integral lock washer). Mount the two 1-1/2" hex standoffs on the left-hand side and secure with KEP nuts, if required.

Once the 7/16" standoffs are mounted, place the 9331A in its place and secure with two 1" hex standoffs on the right-hand side and a 6-32 X 3/8" Phillips pan head screw in the center hole. Attach the 6-conductor ribbon cable supplied with the 9331A kit to the 6 position connector on the 9331A PCBA. Fold the ribbon cable in a right angle, such that the opposite connector is facing up. Mount the 9388B3 board in place and secure with four 1" hex standoffs. Attach the ribbon cable to connector J6 at the bottom of the 9388B3 PCBA, adjacent to switch S1 and S2, by curling the ribbon cable up around the 9388B3 PCBA and inserting it into J6. The ribbon cable is equipped with a plug with polarization (indexing) tabs so that the cable can only be inserted in one way. Replace the logic cover and secure with the four 6-32 X 1/2" Phillips pan head screws.

Current Transformer Mounting

Before mounting the current transformers, make sure that each CT has its leads shorted together, or that the CT's leads are already connected to the 9331A. This will prevent any hazardous voltages and currents while you are installing the CT's. If toroidal (solid core) CT's are used, the power on the main feeder wires **must be turned off** before mounting. If split-core CT's are used, attempt to turn off or minimize the power being used on the service while you are installing and connecting the current transformers.

Mount the current transformers on the main service panel and place the red dot (in some cases a black dot) facing the line side. If split-core current transformers are used, place them so that the arrow is pointing towards the line side. Run the leads to the 9388B3 for connection to the 9331A PCBA and clearly mark each CT with the phase number or letter it is mounted on.

Connections

Refer to Figure 10.0 for the proper service type. Designate each phase in the building A, B, and C. In a DELTA configuration, the high leg (208VAC referenced to neutral) MUST be phase C.

Voltage Tap Connections

Three potential voltage taps are required for the 9331A. Install a 3-pole, 15-Amp circuit breaker for this purpose in the circuit breaker panel nearest the demand controller. Run the appropriate conduit or coupling hardware to connect the circuit breaker panel to the unit. Run four #14 AWG wires to the unit from the circuit breaker panel, one for each phase plus a neutral: black, red, blue and white. Connect to the 9331A board as shown in Table 10.3 below.

Table 10.3 - 9331A Voltage Tap Connections

TB1 Term#	TB1 Label	TB1 Terminal Name (from bottom to top)	WYE	DELTA
1	L1	Phase A Voltage Input	(BLK)	(BLK)
2	L2	Phase B Voltage Input	(RED)	(BLU)
3	L3	Phase C Voltage Input*	(BLU)	(ORG)*
4	N	Neutral	(WHT)	(WHT)

* must be the high leg in a DELTA service

Double-check all voltage tap wires and make sure that all wires are correctly connected to the proper terminals. Note that terminals are numbered from **BOTTOM** to **TOP** as shown in the Figure 10.0. In some applications the board may need to be mounted horizontally below the main board. In this case, the numbering would be LEFT TO RIGHT.

Current Transformer Connections

The 3 current transformers connect to the terminal block TB2. The current transformers MUST be matched up with the proper phase, otherwise power will not read properly. Connect each current transformer to the proper terminals matching the wire color shown in Table 10.4. Secure all wires.

Table 10.4 - Current Transformer Connections

TB2 Term#	TB2 Label	TB2 Terminal Name (from bottom to top)
1	CT1-1	Phase A Current Transformer Input (WHT)
2	CT1-2	Phase A Current Transformer Input (BLK)
3	CT2-1	Phase B Current Transformer Input (WHT)
4	CT2-2	Phase B Current Transformer Input (BLK)
5	CT3-1	Phase C Current Transformer Input (WHT*)
6	CT3-2	Phase C Current Transformer Input (BLK)

* must be the current transformer mounted on the high leg in DELTA applications

Note

The White (WHT) and Black (BLK) wires of each CT may need to be reversed depending on the manufacturer and mounting orientation. Refer to Troubleshooting section on the next page.

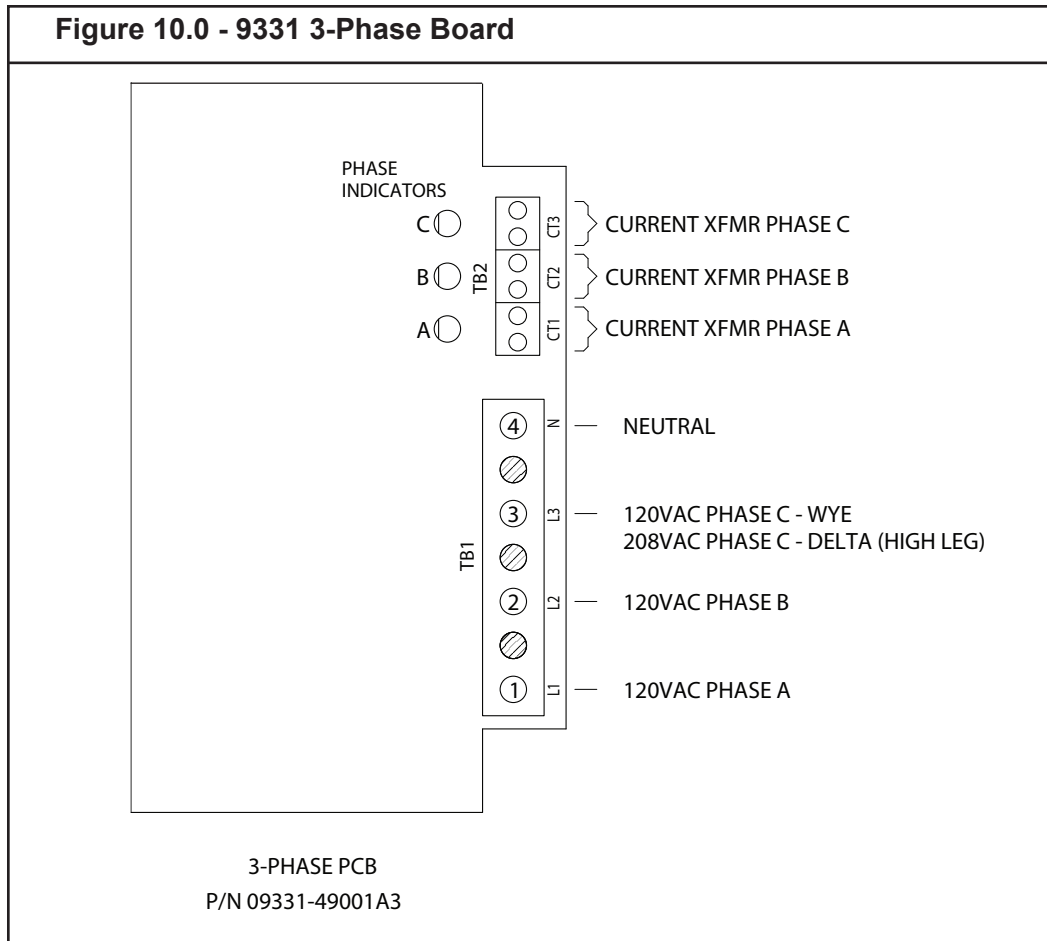

Testing and Programming

Turn on the 9388B3's power supply. The display should light up normally and shed all loads. Enter the System Loop by pressing the pushbutton switch down for five seconds. Follow the system programming sequence in Appendix B of this manual and set all settings for the appropriate mode of operation. When you get to the Demand Range setting (dr), set the lower display to "3P" by pushing the pushbutton switch and rotating the control knob clockwise until the "3P" appears. This will activate the 3-phase input and enable the correct input lines to read the 9331A. The next setting, "FS", sets the Full Scale setting. The setting here is dependent on which CT's you are using and the configuration of the 9331A board. This cannot be set or changed arbitrarily.

The Full Scale setting (FS) MUST be set to the proper setting listed in the tables above for the current transformers and the PCBA configuration you have. Return to the Main Display mode to the Instantaneous Demand (id) display.

Turn on the 3-pole circuit breaker that supplies power to the voltage inputs of the 9331A. Make sure that there is a load of at least 1KW (~5 Amps) on each leg. Look to the left of TB2, the current transformer terminal block, for the three green LED indicators. All three of the green LED indicators should be lit and the 9388B should be accurately measuring power in the "id" display. Turn on a load of known size (on each phase individually, if possible) and verify that power is being properly measured. Verify with an Amp-Clamp by reading current on each phase, if desired.

Troubleshooting

If one or more of the three green LED's on the 9331A fail to light up, turn off the circuit breaker (voltage potentials) and verify that each current transformer is properly matched up with its corresponding voltage phase. Any mismatch may cause one or two of the lights to incorrectly come on but all three won't come on simultaneously. Once you have

determined that all the phasing is correct and you still cannot get all three LED's to light simultaneously with at least 1KW of current being drawn through each phase, perform the following test.

1. Turn power to the system and 9331 3-phase board off.
2. Remove the White and Black wires of CT#2 on Phase B and short the wires together with a wirenut or other suitable means of shorting them together temporarily.
3. Remove the White and Black wires of CT#3 on Phase C and short the wires together with a wirenut or other suitable means of shorting them together temporarily.
4. Turn on power to the 9388B and power to the voltage phases.
5. Make sure there is at least 1KW of load on Phase A.
6. The bottom-most Green LED (#1) on the 9331 3-phase board should be lit.
7. If not, turn off all power, reverse the Black and White leads of CT#1 on TB2 terminals 1 and 2, and repeat test.
8. Turn on power to unit and 3-phase board and insure that there is at least 1KW of load on Phase A. The Green LED (#1) should be lit. (If not, go back again and check the current transformers to insure that they are matched up with the proper voltage phases.)
9. Assuming the Green LED #1 is brightly and solidly lit, then observe the instantaneous demand. Turn the load on and off on this phase to insure that you are seeing the demand go up and down as this load is turned on and off, respectively. Verify that the demand shown in the display is correct by taking a current reading on the phase being measured (Phase A in this first case) with an Amp-Clamp. Multiply the current reading measured by the line voltage for that phase only. You should be within one-half KW (500 watts) of what is shown on the display.
10. Once you get Phase A operating and reading power correctly, be sure to note the correct connection of the Phase A CT's Black and White wires. Disconnect them from terminals #TB2-1 and #TB2-2 and short them together so you can perform the test on Phase B (and subsequently Phase C) without any interference from Phase A.
11. Repeat the test with Phase B using terminals TB2-3 and TB2-4.
12. Repeat the test with Phase C using terminals TB2-5 and TB2-6.
13. When you get each Phase operating correctly, reconnect each CT's wires to their respective terminals and retest the entire system. Take readings with the Amp-Clamp and insure that the demand displayed in the Instantaneous Demand (id) is correct. Use the following formula to calculate the correct KW power on the service:

$$KW = (I_A + I_B + I_C) \times V_{line} \times .577$$

Where I_x is the current on each phase
 V_{line} is the line voltage of the service, with reference to neutral.
14. If the load's value appears to go up and down correctly but is off by a factor of two, check the Full Scale setting (FS) to make sure that it is set for the right combination of the 9331 board version and the CT ratio.

Contact your dealer or Brayden Automation Corporation for help in troubleshooting the installation of the 9331 3-phase power adapter board.

Appendix A - Glossary

The following terms used throughout this manual are defined here to assist you in understanding their meaning and use.

Average Energy Cost	Total energy costs divided by kilowatt-hours (KWh).
Average Demand	The average rate of electric usage during the demand averaging period. The average demand is calculated by dividing the total number of kilowatt-hours used by the number of hours in the averaging period. For example, if 45 KWh's were used during an averaging period of 15 minutes, the average demand would equal 45 divided by .25 (15 minutes) or 180 KW.
Averaging Period	An interval of 15, 30 or 60 minutes during which the average demand is calculated. The demand management system should be set to the same interval as the averaging period of the utility's demand meter.
Controlled Load	An energy-consuming device or devices whose electrical supply is temporarily shut off by a demand management system. Also see Control Point.
Controller	Another term for a Demand Management System.
Control Point	Each control point represents one or more energy consuming devices or loads whose electrical supply can be temporarily shut off by a demand management system. Also see Controlled Load.
Customer Charge	A flat charge on an energy bill used to help the utility company recover fixed costs associated with serving a customer. It is independent of the demand or consumption of the energy provided. Also called monthly service charge or basic charge.
Customer Classes	A way of classifying customers according to similar characteristics, such as level of demand, usage, location and load pattern. These characteristics are classified together for setting electric rates. Customer classes include residential, commercial, industrial and agricultural. Furthermore, the commercial class may be segmented into Medium General Service and Large General Service.
Declining Block Rate	A method of charging for electric service used by electric utilities based on total energy consumed (KWh) and cost per KWh. The cost per KWh is usually reduced as total KWh use increases.
Demand	The rate of use of electrical power during a certain period of time, expressed in KW (or kilowatts).
Demand Billing Rate	A utility's method of charging for electric service where the cost of electricity used is based on both total energy consumed (KWh) and demand peak (KW).
Demand Charge	A charge that recovers some of a utility's capital and operating costs. It appears on an electric bill, along with the customer charge and the energy charge.
Demand Limit	The set point, expressed in KW, below which energy is being consumed. As this limit is approached, the 9388B begins shutting off pre-determined loads to control demand.
Demand Management System	A device that monitors electrical usage and temporarily sheds (turns off) one or more energy consuming devices as necessary to level out energy consumed within any demand interval.
Demand Meter	A utility meter which measures both total energy consumed in KWh and the highest average demand peak in KW.

Demand Peak	The highest average KW demand over the billing period. Averages may be determined over 15-, 30- or 60-minute intervals depending upon the utility. Same as Peak Demand.
Demand Ratchet	A method that typically determines the minimum demand charge on an electric bill for the next 12 months based on a percentage of the maximum demand of the previous 12 months.
Demand Rate	A method of charging for electric service based on the cost of electricity used on both total energy consumed (KWh) and demand peak (KW).
Energy Charge	A charge that recovers a utility's operating costs to produce or buy electricity. It appears on an electric bill, along with the customer charge and the demand charge.
Energy Rate	A utility's method of charging for electric service where the cost of electricity is based only on KWh consumption multiplied by a fixed cost per KWh. Cost per KWh remains the same regardless of the number of KWh's used. Also called "Flat" Rate.
Holidays	Days that are considered Off-Peak in Time-of-Use electric rates.
Instantaneous Demand	The electricity, in kilowatts, currently being drawn by the electrical service of a building at any instant in time.
Kilowatt (KW)	1,000 watts. A measure of an electric load's size or how much power it demands.
Kilowatt-Hour (KWh)	The basic measurement of electric power (energy) consumption as metered by the electric utility. (If you were to turn on ten 100 watt lights for one hour, you would have consumed one kilowatt hour of electrical energy.)
Load	The amount of electricity used by a particular energy consuming device or group of devices. Usually expressed in watts or kilowatts.
Load Diversity	The natural, random or regular on/off cycle of all loads in a building.
Load Factor	The ratio of actual kilowatt-hours used to the total possible kilowatt-hours that could have been used at the peak KW demand, if the energy would have been consumed uniformly at the maximum rate of demand over the entire period.
Load Management	The control of demand by temporarily shutting off pre-defined electrical loads.
Load Management Hardware	Equipment, such as the Energy Sentry Demand Management System, used to temporarily shut off energy consuming devices during peak periods.
Load Status	Indicates whether a controlled load is off or on.
Megawatt (MW)	1,000,000 watts or 1,000 kilowatts.
Meter	A device that measures levels and accumulation of electricity use.
Minimum-Off Time	The minimum time that a control point must be shut off before it can be restored by the demand management system. Minimum-off time can be set from 0 to 20 minutes. Control points having a heat pump or air conditioner compressor or other motor load connected to it should have a minimum-off time defined as at least 4 minutes. Resistive loads should not have minimum-off times.
Minimum-On Time	The minimum time that a control point must be restored before it can be shed by the demand management system. Minimum-on time can be set from 0 to 20 minutes. Control points having a heat pump or air conditioner compressor or other motor load connected to it should have a minimum-on time defined as at least 5 minutes.

Off-Peak Demand	Highest average demand reached during the off-peak period as defined by a Time-of-Use Rate.
Off-Peak Demand Limit	The point, expressed in KW, below which energy is being consumed during the off-peak period. As this limit is approached, the 9388B begins shutting off pre-determined loads to control energy demand during the off-peak period. The off-peak demand limit is commonly set to “OFF” so as not to affect any control if there is no off-peak demand charge.
Off-Peak Time-of-Day	The period as defined by a Time-of-Use (TOU) Rate during which energy demand is the lowest and the utility is well below its system peak. See also Time-of-Use Demand Rate.
On-Peak Demand	The highest average demand reached during the on-peak period as defined by a Time-of-Use Rate.
On-Peak Demand Limit	See Demand Limit.
On-Peak Time-of-Day	The period as defined by a Time-of-Use (TOU) Rate during which energy demand is the greatest and the utility is at or near its system peak. See also Time-of-Use Demand Rate.
Peak Demand	The highest demand that has occurred during any one averaging period during the billing period. This is the number captured by your meter and used by your utility company to calculate the KW demand charge on your bill, if you are on a Demand-based billing rate.
Peak Load	The greatest amount of electricity consumed over a stated period of time.
Peak Period	The averaging period or interval during which the highest peak demand occurs.
Priority	The relative importance of each controlled load to all other controlled loads, as assigned in the 9388B. As the demand approaches the demand limit, the demand management system uses the priority of each load to determine which loads to shut off first. A load with a priority of “1” is the highest priority and is shed last and restored first. A load with a priority of “8” is the lowest priority and is shed first and restored last (assuming that the controller has 8 active control points). Loads of equal priority will rotate being shed and restored.
Rate Structure	The format for utility pricing of electric customers.
Restore	To make power available to a load.
Shed	To turn a load off.
Time-Of-Use Demand Rate	A method of charging for electric service used by electric utilities which charges a higher price for KWh’s used in on-peak periods and a lower price for KWh’s used in the off-peak periods. The demand peak is usually monitored and recorded only in the on-peak periods. The cost of electricity is based on both total energy consumed (KWh) and demand peak (KW). Depending on the particular utility and rate, one or more on-peak periods, varying in length, may exist during a 24-hour period.
Uncontrolled Load	A load which is not connected to or controlled by the demand management system but is measured as part of the building’s total demand.
Watt	A measure of electrical power or rate of doing work. It is analogous to horsepower where one horsepower is equivalent to approximately 746 watts.

Appendix B - Settings

Main Loop Settings

Display Function	Default	Description	Allowable Range	Current Setting
id		Instantaneous Demand	N/M	----
Ad		Average Demand	N/M	----
Pd		Peak Demand	N/M ²	----
dL		On-Peak Demand Limit (KW)	SHEd, 2.0-49.5; 4-99; 8-198; 20-495; 50-990	
LS		Load Status Control Pts. 1-8	N/M	----
LU ¹		Load Status Control Pts. 9-16	N/M	----
CL		Clock (Military)	0:00-23:59	(Current Time)

¹ Load status for the upper bank of control points (9-16) that appears when the Number of Relays setting (nr) is greater than 8. The relay expansion board or PLC transmitter must be installed to use control points 9-16.

² Denotes a non-modifiable value except to reset Peak Demand

System Loop Settings

Display Function	Default	Description	Allowable Range	Current Setting
dE	X	Current Temperature inside Controller	N/M	Current Temp
do	X	Set Day of Week: 1 = Sun. 7 = Sat.	1-7	Current Day
dA	X	Set the Month/Day	1/1 – 12/31	Current Date
Yr	X	Set the Current Year	1992-2090	Current Year
dS	2	Enable/Disable Automatic Daylight Saving Time Adjustment	0, 1, 2	
nS	2 ³	Set Number of Seasons	0-4	
A1	5:55	Set the Start Time of On-Peak Period #1	0:00-23:59	
A2	13:05	Set the End Time of On-Peak Period #1	0:00-23:59	
A3	11:55	Set the Start Time of On-Peak Period #2	0:00-23:59	
A4	21:05	Set the End Time of On-Peak Period #2	0:00-23:59	
Ad	10/1	Set the Start Date of the Winter Rates	0/0-12/31	
U1		Set the Start Time of On-Peak Period #1	0:00-23:59	
U2		Set the End Time of On-Peak Period #1	0:00-23:59	
U3		Set the Start Time of On-Peak Period #2	0:00-23:59	
U4		Set the End Time of On-Peak Period #2	0:00-23:59	
Ud		Set the Start Date of the Spring Rates	0/0-12/31	
S1	8:55	Set the Start Time of On-Peak Period #1	0:00-23:59	
S2	22:05	Set the End Time of On-Peak Period #1	0:00-23:59	
S3	0:00	Set the Start Time of On-Peak Period #2	0:00-23:59	
S4	0:00	Set the End Time of On-Peak Period #2	0:00-23:59	

Display Function	Default	Description	Allowable Range	Current Setting
Sd	4/1	Set the Start Date of the Summer Rates	0/0-12/31	
F1		Set the Start Time of On-Peak Period #1	0:00-23:59	
F2		Set the End Time of On-Peak Period #1	0:00-23:59	
F3		Set the Start Time of On-Peak Period #2	0:00-23:59	
F4		Set the End Time of On-Peak Period #2	0:00-23:59	
Fd		Set the Start Date of the Fall Rates	0/0-12/31	
SS	on	Set Weekends to On-Peak or Off-Peak	on/oFF	
H1	1/1	Set Holiday #1	0/0-12/31	
H2	7/4	Set Holiday #2	0/0-12/31	
H3	12/25	Set Holiday #3	0/0-12/31	
H4	0/0	Set Holiday #4	0/0-12/31	
H5	onP	Set Holiday #5 (President's Day)	1/1-12/31, onP, oFFP	
H6	onP	Set Holiday #6 (Memorial Day)	1/1-12/31, onP, oFFP	
H7	onP	Set Holiday #7 (Labor Day)	1/1-12/31, onP, oFFP	
H8	onP	Set Holiday #8 (Thanksgiving Day)	1/1-12/31, onP, oFFP	
H9	onP	Set Holiday #9 (Friday after Thanksgiving)	1/1-12/31, onP, oFFP	
oP	X	Off-Peak Peak Demand	NM ²	
oL	oFF	Set Off-Peak Demand Limit	2.0-49.5; 4-99; 8-198; 20-495; 50-990; oFF	
HL	oFF	Set Maximum Instantaneous Demand Limit	2.0-49.5; 4-99; 8-198; 20-495; 50-990;	
db	on	Enable/Disable Display Saver	on, oFF	
nr	8	Set Number of Relays Used	1-16	
Pr1	1	Set Priority for Relay #1	1-17	
Pr2	2	Set Priority for Relay #2	1-17	
Pr3	3	Set Priority for Relay #3	1-17	
Pr4	4	Set Priority for Relay #4	1-17	
Pr5	5	Set Priority for Relay #5	1-17	
Pr6	6	Set Priority for Relay #6	1-17	
Pr7	7	Set Priority for Relay #7	1-17	
Pr8	8	Set Priority for Relay #8	1-17	
Pr9	9	Set Priority for Relay #9	1-17	
Pr10	10	Set Priority for Relay #10	1-17	
Pr11	11	Set Priority for Relay #11	1-17	
Pr12	12	Set Priority for Relay #12	1-17	
Pr13	13	Set Priority for Relay #13	1-17	
Pr14	14	Set Priority for Relay #14	1-17	
Pr15	15	Set Priority for Relay #15	1-17	
Pr16	16	Set Priority for Relay #16	1-17	
on1	0	Set Minimum-On Time for Relay #1	0-20 minutes	
on2	8	Set Minimum-On Time for Relay #2	0-20 minutes	

Display Function	Default	Description	Allowable Range	Current Setting
on3	8	Set Minimum-On Time for Relay #3	0-20 minutes	
on4	0	Set Minimum-On Time for Relay #4	0-20 minutes	
on5	0	Set Minimum-On Time for Relay #5	0-20 minutes	
on6	0	Set Minimum-On Time for Relay #6	0-20 minutes	
on7	0	Set Minimum-On Time for Relay #7	0-20 minutes	
on8	0	Set Minimum-On Time for Relay #8	0-20 minutes	
on9	0	Set Minimum-On Time for Relay #9	0-20 minutes	
on10	0	Set Minimum-On Time for Relay #10	0-20 minutes	
on11	0	Set Minimum-On Time for Relay #11	0-20 minutes	
on12	0	Set Minimum-On Time for Relay #12	0-20 minutes	
on13	0	Set Minimum-On Time for Relay #13	0-20 minutes	
on14	0	Set Minimum-On Time for Relay #14	0-20 minutes	
on15	0	Set Minimum-On Time for Relay #15	0-20 minutes	
on16	0	Set Minimum-On Time for Relay #16	0-20 minutes	
oF1	0	Set Minimum-Off Time for Relay #1	0-20 minutes	
oF2	5	Set Minimum-Off Time for Relay #2	0-20 minutes	
oF3	5	Set Minimum-Off Time for Relay #3	0-20 minutes	
oF4	0	Set Minimum-Off Time for Relay #4	0-20 minutes	
oF5	0	Set Minimum-Off Time for Relay #5	0-20 minutes	
oF6	0	Set Minimum-Off Time for Relay #6	0-20 minutes	
oF7	0	Set Minimum-Off Time for Relay #7	0-20 minutes	
oF8	0	Set Minimum-Off Time for Relay #8	0-20 minutes	
oF9	0	Set Minimum-Off Time for Relay #9	0-20 minutes	
oF10	0	Set Minimum-Off Time for Relay #10	0-20 minutes	
oF11	0	Set Minimum-Off Time for Relay #11	0-20 minutes	
oF12	0	Set Minimum-Off Time for Relay #12	0-20 minutes	
oF13	0	Set Minimum-Off Time for Relay #13	0-20 minutes	
oF14	0	Set Minimum-Off Time for Relay #14	0-20 minutes	
oF15	0	Set Minimum-Off Time for Relay #15	0-20 minutes	
oF16	0	Set Minimum-Off Time for Relay #16	0-20 minutes	
dC	1	Set Demand Control Algorithm	1-5	
AP	15	Set Demand Averaging Period	15, 30, 60	
dr	40	Set Demand Range	40, 80, 3P, PULS	
FS ⁴	50	Set Full Scale	50, 100, 200, 500, 999.9	
PC ⁵	25.5	Set Pulse Constant	.1-604.3	
Fi	on	Enable/Disable Fast Instantaneous Display	on, oFF	

³ The default Number of Season (nS) is "2" meaning that only the winter and summer daily peak periods will be available in the System Loop. If you change this to "3" then the spring periods will be available and if it's set to "4", all 4 seasons' peak periods will be available.

⁴ Full Scale (FS) only appears if "3P" or "PULS" is selected in the "dr" setting.

⁵ Pulse Constant (PC) only appears if "PULS" is selected in the "dr" setting.

Auto-Limit Loop Settings

Display Function	Default	Description	Allowable Range	Current Setting
d1	0/0	Start Date – Period 1	0/0-12/31	
L1	6	On-Peak Demand Limit – Period 1	2.0-49.5; 4-99; 8-198; 20-495; 50-990	
o1	oFF	Off-Peak Demand Limit – Period 1	2.0-49.5; 4-99; 8-198; 20-495; 50-990; oFF	
d2	0/0	Start Date – Period 2	0/0-12/31	
L2	6	On-Peak Demand Limit – Period 2	2.0-49.5; 4-99; 8-198; 20-495; 50-990	
o2	oFF	Off-Peak Demand Limit – Period 2	2.0-49.5; 4-99; 8-198; 20-495; 50-990; oFF	
d3	0/0	Start Date – Period 3	0/0-12/31	
L3	6	On-Peak Demand Limit – Period 3	2.0-49.5; 4-99; 8-198; 20-495; 50-990	
o3	oFF	Off-Peak Demand Limit – Period 3	2.0-49.5; 4-99; 8-198; 20-495; 50-990; oFF	
d4	0/0	Start Date – Period 4	0/0-12/31	
L4	6	On-Peak Demand Limit – Period 4	2.0-49.5; 4-99; 8-198; 20-495; 50-990	
o4	oFF	Off-Peak Demand Limit – Period 4	2.0-49.5; 4-99; 8-198; 20-495; 50-990; oFF	
d5	0/0	Start Date – Period 5	0/0-12/31	
L5	6	On-Peak Demand Limit – Period 5	2.0-49.5; 4-99; 8-198; 20-495; 50-990	
o5	oFF	Off-Peak Demand Limit – Period 5	2.0-49.5; 4-99; 8-198; 20-495; 50-990; oFF	
d6	0/0	Start Date – Period 6	0/0-12/31	
L6	6	On-Peak Demand Limit – Period 6	2.0-49.5; 4-99; 8-198; 20-495; 50-990	
o6	oFF	Off-Peak Demand Limit – Period 6	2.0-49.5; 4-99; 8-198; 20-495; 50-990; oFF	
d7	0/0	Start Date – Period 7	0/0-12/31	
L7	6	On-Peak Demand Limit – Period 7	2.0-49.5; 4-99; 8-198; 20-495; 50-990	
o7	oFF	Off-Peak Demand Limit – Period 7	2.0-49.5; 4-99; 8-198; 20-495; 50-990; oFF	
d8	0/0	Start Date – Period 8	0/0-12/31	
L8	6	On-Peak Demand Limit – Period 8	2.0-49.5; 4-99; 8-198; 20-495; 50-990	
o8	oFF	Off-Peak Demand Limit – Period 8	2.0-49.5; 4-99; 8-198; 20-495; 50-990; oFF	
d9	0/0	Start Date – Period 9	0/0-12/31	

Display Function	Default	Description	Allowable Range	Current Setting
L9	6	On-Peak Demand Limit – Period 9	2.0-49.5; 4-99; 8-198; 20-495; 50-990	
o9	oFF	Off-Peak Demand Limit – Period 9	2.0-49.5; 4-99; 8-198; 20-495; 50-990; oFF	
dA	0/0	Start Date – Period A	0/0-12/31	
LA	6	On-Peak Demand Limit – Period A	2.0-49.5; 4-99; 8-198; 20-495; 50-990	
oA	oFF	Off-Peak Demand Limit – Period A	2.0-49.5; 4-99; 8-198; 20-495; 50-990; oFF	
dB	0/0	Start Date – Period B	0/0-12/31	
LB	6	On-Peak Demand Limit – Period B	2.0-49.5; 4-99; 8-198; 20-495; 50-990	
oB	oFF	Off-Peak Demand Limit – Period B	2.0-49.5; 4-99; 8-198; 20-495; 50-990; oFF	
dC	0/0	Start Date – Period C	0/0-12/31	
LC	6	On-Peak Demand Limit – Period C	2.0-49.5; 4-99; 8-198; 20-495; 50-990	
oC	oFF	Off-Peak Demand Limit – Period C	2.0-49.5; 4-99; 8-198; 20-495; 50-990; oFF	
nd	5	# of Days of Offset	1-9	

Appendix C - Warranty Information

Installing Electrician: Fill out applicable information on this page.

1. Strategy selected (check applicable strategy):

Fixed Rotating Combination Fixed/Rotate

Control Point	Load Priority	Assignment/Description (if applicable)	Minimum-On/Off Time (if applicable)
1	_____	_____	mins On ___/Off ___
2	_____	_____	mins On ___/Off ___
3	_____	_____	mins On ___/Off ___
4	_____	_____	mins On ___/Off ___
5	_____	_____	mins On ___/Off ___
6	_____	_____	mins On ___/Off ___
7	_____	_____	mins On ___/Off ___
8	_____	_____	mins On ___/Off ___
9	_____	_____	mins On ___/Off ___
10	_____	_____	mins On ___/Off ___
11	_____	_____	mins On ___/Off ___
12	_____	_____	mins On ___/Off ___
13	_____	_____	mins On ___/Off ___
14	_____	_____	mins On ___/Off ___
15	_____	_____	mins On ___/Off ___
16	_____	_____	mins On ___/Off ___

Owner:

- Record circuit assignments above.
- Fill out warranty card and mail today!
- Record items below for your records:

Date of Installation: _____

Serial Number: _____

Installing Electrical Contractor: _____

Phone #: _____

LIMITED THREE-YEAR WARRANTY

Energy Sentry Demand Management Systems and their components are warranted by Brayden Automation Corporation against defects in materials and workmanship for three (3) years from the date of original installation, provided that the original date of installation is within one year from date of manufacture. This warranty is further conditioned upon the Energy Sentry Demand Management Systems being properly installed and used for their ordinary and intended purposes. During the term of this warranty, Brayden Automation Corporation, through its authorized representative, will repair, or at its option, replace at no charge an Energy Sentry Demand Management System or its components that are proven to be defective, provided that you comply with the requirements set forth in this warranty.

WARRANTY REQUIREMENTS AND CONDITIONS

1) The limited warranties contained herein extend exclusively to the original purchaser of the Energy Sentry 9388B Demand Management System. If you sell your building after installation of the 9388B, this warranty is non-transferable to the new owner(s).

2) The 9388B must be installed by a duly-qualified electrical contractor who is appropriately licensed in the jurisdiction or an authorized dealer representative. Any removal and/or reinstallation must be done by a duly-qualified and licensed electrical contractor (within the appropriate jurisdiction) or authorized dealer representative.

3) Repairs or replacement shall be undertaken by duly authorized service dealers or Brayden Automation Corporation. If you or any member of your company or any other unauthorized person manipulates, moves, alters, damages or attempts to repair or replace the Energy Sentry Demand Management System, the warranty shall be void and of no effect.

4) Notification to Brayden Automation Corporation or its authorized dealer under this warranty must be received within one week after discovering any defect in materials or workmanship.

5) If the Energy Sentry 9388B Demand Management System is removed and returned to the authorized service dealer or Brayden Automation Corporation, 6230 Aviation Circle, Loveland, CO 80538 for repair or replacement under this warranty, all shipping and handling charges must be prepaid by you. Transit damage is not covered by the warranty and Brayden Automation Corporation suggests you insure shipments to the service dealer or to the factory. Remember to send proof of date of installation as well as the serial number of the unit which is located on the inside of the Control/Relay Unit.

6) The warranty does not apply if the Energy Sentry 9388B Demand Management System has been damaged by accident, alterations, abuse, misuse, improper installation, or act of nature, or as a result of service or modifications by someone other than an authorized factory representative.

7) In no event will Brayden Automation Corporation be liable for any lost profits, lost savings, incidental damages or other economic consequential damages, even if Brayden Automation Corporation has been advised of the possibility of such damages due to the proper or improper workings of

the Energy Sentry 9388B Demand Management System.

8) This warranty is for factory service only. Brayden Automation Corporation will not be responsible for any field service expense for a licensed electrician or authorized service representative to service the Energy Sentry 9388B Demand Management System during or after the warranty period is in effect.

This warranty is expressly made in lieu of any other warranties expressed or implied specifically including any warranty of merchantability or fitness for a particular purpose.

This warranty is further conditioned on the return and receipt of the Warranty Registration Card.

This warranty gives you specific legal rights, and you may have other rights which vary from state to state.

Appendix D - System Planning Form

Building Electrical Layout

Draw brief layout of building.

This information should be used to estimate installation cost by determining:

1. Where demand controller will be installed
2. Distance from meter to controller
3. Distance from controller to remote relays and/or controlled loads
4. Meter location
5. Circuit breaker panel location
6. Location of all potential controlled loads (using load numbers above)

Electrical Service

Service Size: _____ Amps or _____ KW

Configuration: 1-Phase: _____ 120/240v (9388BA)
 3-Phase: _____ 120/208v 4 wire Y (9388BY)
 _____ 120/240v 4 wire Δ (9388BD)

Pulse Input (9388BP)

2-wire: _____ 3-wire: _____

Pulse Constant: Form A or Form C

Current Transformers

- Single Phase (9388BA) 3-Phase (9388B3)

If Pulse Output Meter is not available for use, specify quantity and type of current transformers:

- 200A (Std) – 1.35" – 1000:1 – Solid – P/N 8420-3028
- 400A (Lg) – 2.25" – 2000:1 – Solid – P/N 8420-3029 3 Sets of 3
- 400A (X-Lg) – 3.5" – 2000:1 – Solid – P/N 8420-3030
- 800A (X-Lg) – 3.5" – 4000:1 – Solid – P/N 8420-3031
- 200A (Std) – 1.25" – 1000:1 – Split – P/N 8420-3039
- 400A (X-Lg) – 2.5" sq. – 2000:1 – Split – P/N 8420-3040
- 400A (Lg) – 1.75" sq. – 2000:1 – Split – P/N 8420-3041
- 800A (X-Lg) – 4.0" sq. – 4000:1 – Split – P/N 8420-3042
- 200A (Sm) – .75" sq. – 1000:1 – Split – P/N 8420-3043

Load Survey

Total Estimated Connected Load: _____ KW Historical Peak Demand: _____ KW

Note: List compressors and heat strips of heat pumps separately.

Load #	Description/Location	Controlled By (Check One)								Priority # (1=high, 16=low) (Determine relative priority of controlled loads)
		SPST-NC LV	DTST-NC-LV	SPST-NC-PWR	DPST-NC-PWR	1021 PLC	1022 PLC	1024 PLC	1031 PLC	
1	_____	<input type="checkbox"/>	<input type="checkbox"/>	<input type="checkbox"/>	<input type="checkbox"/>	<input type="checkbox"/>	<input type="checkbox"/>	<input type="checkbox"/>	<input type="checkbox"/>	_____
2	_____	<input type="checkbox"/>	<input type="checkbox"/>	<input type="checkbox"/>	<input type="checkbox"/>	<input type="checkbox"/>	<input type="checkbox"/>	<input type="checkbox"/>	<input type="checkbox"/>	_____
3	_____	<input type="checkbox"/>	<input type="checkbox"/>	<input type="checkbox"/>	<input type="checkbox"/>	<input type="checkbox"/>	<input type="checkbox"/>	<input type="checkbox"/>	<input type="checkbox"/>	_____
4	_____	<input type="checkbox"/>	<input type="checkbox"/>	<input type="checkbox"/>	<input type="checkbox"/>	<input type="checkbox"/>	<input type="checkbox"/>	<input type="checkbox"/>	<input type="checkbox"/>	_____
5	_____	<input type="checkbox"/>	<input type="checkbox"/>	<input type="checkbox"/>	<input type="checkbox"/>	<input type="checkbox"/>	<input type="checkbox"/>	<input type="checkbox"/>	<input type="checkbox"/>	_____
6	_____	<input type="checkbox"/>	<input type="checkbox"/>	<input type="checkbox"/>	<input type="checkbox"/>	<input type="checkbox"/>	<input type="checkbox"/>	<input type="checkbox"/>	<input type="checkbox"/>	_____
7	_____	<input type="checkbox"/>	<input type="checkbox"/>	<input type="checkbox"/>	<input type="checkbox"/>	<input type="checkbox"/>	<input type="checkbox"/>	<input type="checkbox"/>	<input type="checkbox"/>	_____
8	_____	<input type="checkbox"/>	<input type="checkbox"/>	<input type="checkbox"/>	<input type="checkbox"/>	<input type="checkbox"/>	<input type="checkbox"/>	<input type="checkbox"/>	<input type="checkbox"/>	_____
9	_____	<input type="checkbox"/>	<input type="checkbox"/>	<input type="checkbox"/>	<input type="checkbox"/>	<input type="checkbox"/>	<input type="checkbox"/>	<input type="checkbox"/>	<input type="checkbox"/>	_____
10	_____	<input type="checkbox"/>	<input type="checkbox"/>	<input type="checkbox"/>	<input type="checkbox"/>	<input type="checkbox"/>	<input type="checkbox"/>	<input type="checkbox"/>	<input type="checkbox"/>	_____
11	_____	<input type="checkbox"/>	<input type="checkbox"/>	<input type="checkbox"/>	<input type="checkbox"/>	<input type="checkbox"/>	<input type="checkbox"/>	<input type="checkbox"/>	<input type="checkbox"/>	_____
12	_____	<input type="checkbox"/>	<input type="checkbox"/>	<input type="checkbox"/>	<input type="checkbox"/>	<input type="checkbox"/>	<input type="checkbox"/>	<input type="checkbox"/>	<input type="checkbox"/>	_____
13	_____	<input type="checkbox"/>	<input type="checkbox"/>	<input type="checkbox"/>	<input type="checkbox"/>	<input type="checkbox"/>	<input type="checkbox"/>	<input type="checkbox"/>	<input type="checkbox"/>	_____
14	_____	<input type="checkbox"/>	<input type="checkbox"/>	<input type="checkbox"/>	<input type="checkbox"/>	<input type="checkbox"/>	<input type="checkbox"/>	<input type="checkbox"/>	<input type="checkbox"/>	_____
15	_____	<input type="checkbox"/>	<input type="checkbox"/>	<input type="checkbox"/>	<input type="checkbox"/>	<input type="checkbox"/>	<input type="checkbox"/>	<input type="checkbox"/>	<input type="checkbox"/>	_____
16	_____	<input type="checkbox"/>	<input type="checkbox"/>	<input type="checkbox"/>	<input type="checkbox"/>	<input type="checkbox"/>	<input type="checkbox"/>	<input type="checkbox"/>	<input type="checkbox"/>	_____

List of Changes

01/30/08

Requested from Bill, 15 diagrams to be placed in the manual. All has been laid out using Bill's body copy and after the diagrams are place, I'll be ready for review.

Document Specs

Top Margin: 1 in
Bottom Margin: .5 in
Inside Margin: .85 in
Outside Margin: .85 in

02/06/08

Changed the line around the charts to 1 pt instead of 3 pt and changed the inner margin from .75 in to .85 in

02/07/08

Per Bill, both inside and outside margins were changed to .85 inches
H1 was changed from 18pt to 20 pt
Chapter titles was changed from 24 pt to 26 pt
Caution tabs were changed to left justified and one inch indents
Note tabs were changed to left justified and one inch indents
Body copy is now completely left justified
H2 is also completely left justified
Graphics were put in a box that was 5.5 x 3.8819 and they were centered based on the guides added into the master at .5 and 1 1/2 hash marks on either side

02/12/08

We decided to not have figure 4.5 in the manual but did add the digital display modes diagram
I also switched the Load Survey and Building Electrical Layout so that all of the Load Survey could be on one page. This has not yet been approved by Bill.

02/15/08

I just finished proofing and have decided that we have way too many capitalized words. There is a time and a place for that, but I think we're over-using it, which makes the document harder to read. Words that used to be capped mid-sentence, that I'm uncapitalizing are: minimum-on/off time, demand limit, on/off-peak (unless they are at the beginning of the sentence or discussing a title of a specific setting in the loops).

2/20/08

We've decided to have each section start it's own page. I have just completed this change which added 5 more pages to the manual.

1/2/09

Added warranty page

4-22-10

Added loads 9-16. Had to change pages 54- end.



BRAYDEN
AUTOMATION

6230 Aviation Circle
Loveland, CO 80538
Phn 970.461.9600
Fax 970.461.9605
www.brayden.com

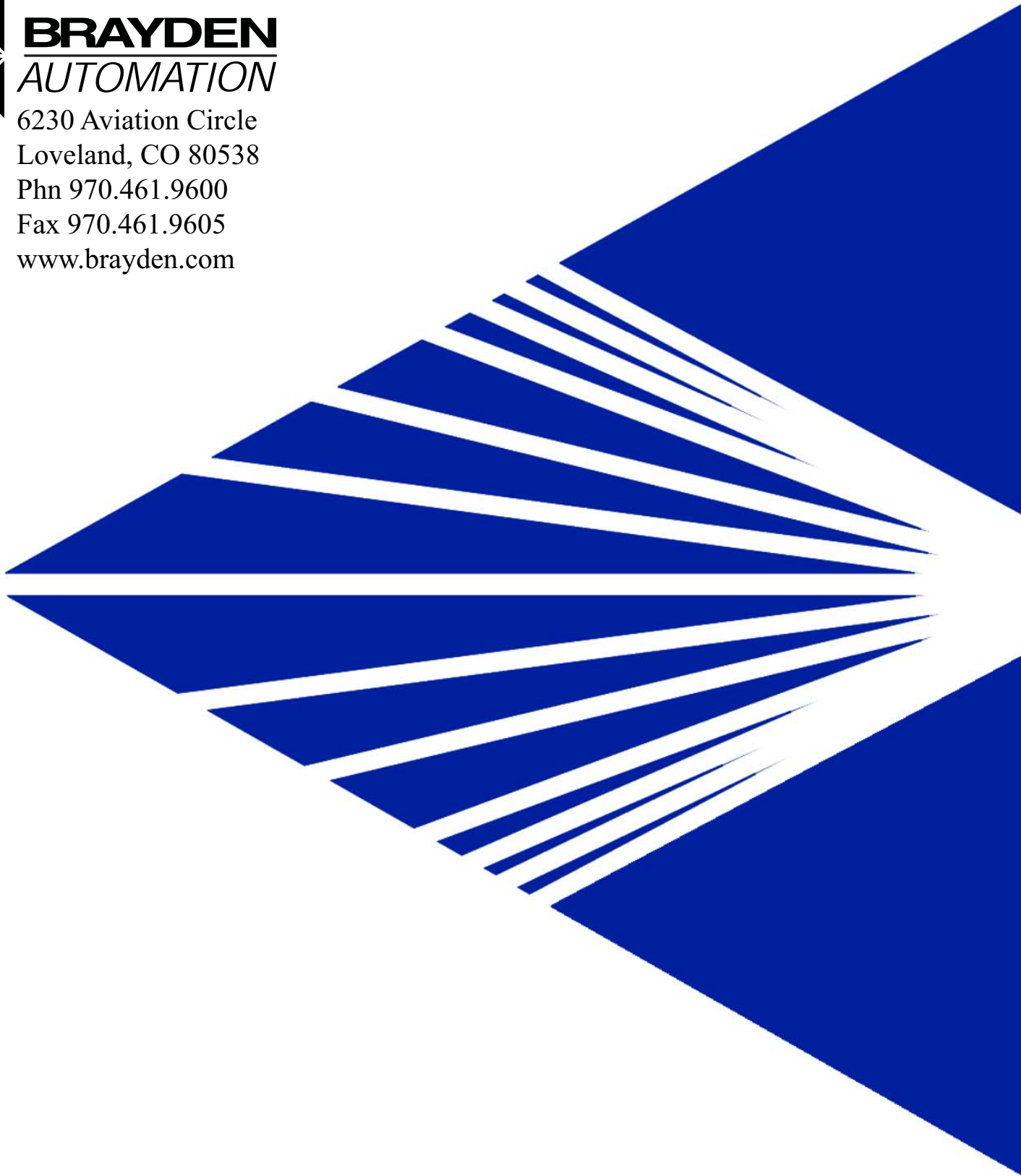

ENERGY
SENTRY®